

Copyright. All information furnished within this document, electronic file or design correspondence is the property of Den Hartog Industries, Inc. and shall not be used, disclosed to others or copied without the expressed written consent of Den Hartog Industries, Inc.

CAUTION LABEL 14676

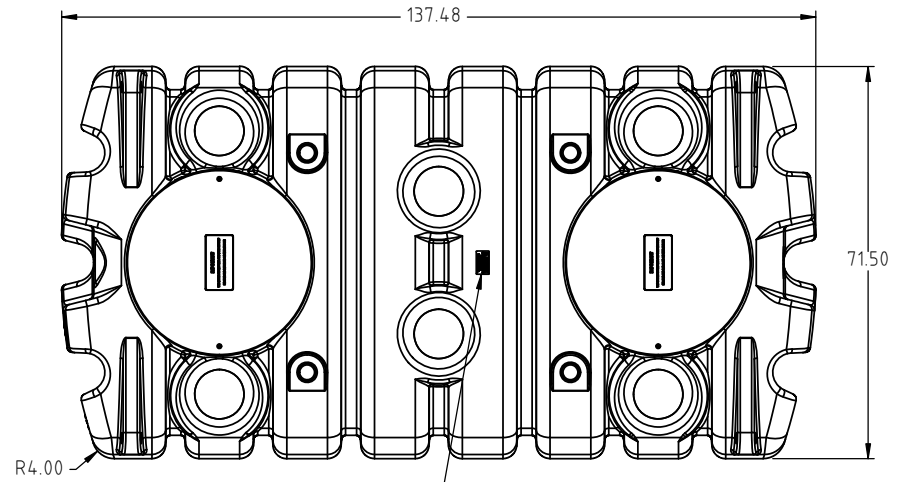

STANDARD TANK SENT WITH TWO 19465 SHIPPING COVERS BUT BURIAL LID(S) AND/OR RISER(S) REQUIRED FOR FINAL INSTALLATION.

BOLT, 3/8" X 1" HEX GR 5 ZINC
P.N.:10089
X 4

WASHER, 3/8" FLAT ZINC
P.N.:SJ10937
X 4

INSTALLED 4" PVC SUPPORTS
P.N.: 14682
X 4

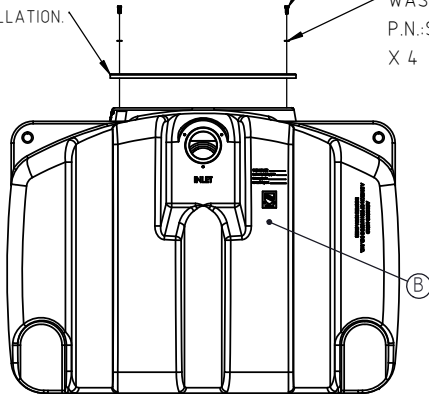

INLET SIDE

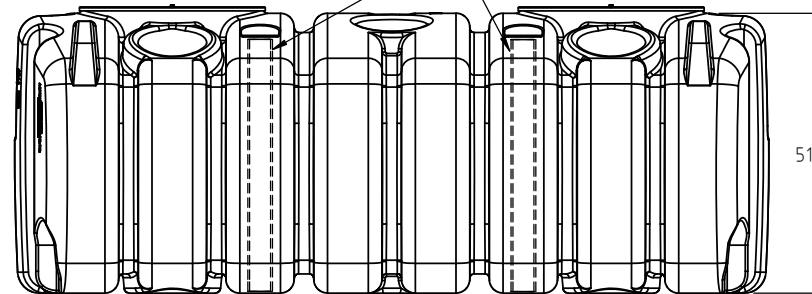

51.00 OUTLET SIDE

B	MOLDED IN INFORMATION REMOVED FROM PRINT	ADH	1/11/2022	4229	DRAWN / DATE ADH 12/2/2016	MATERIAL :
A	638 LBS. WAS 588 LBS.	ADH	1/8/2019	3695	APPRD. / DATE REH 9/8/2017	
REV.	DESCRIPTION	BY	DATE	CCN	SHOT WEIGHT:	NOTES:
ALL DIMENSIONS ARE IN DECIMAL INCHES TOLERANCES UNLESS OTHERWISE SPECIFIED		THIRD ANGLE PROJECTION ANSI 14.5M			SHIPPING WEIGHT: 638.00 LBS.	
POLYETHYLENE ±1% @ 68°F		METAL DECIMAL ± .125" FRACTION ± 1/4" ANGLE ± 1°		FINISH:		

Den Hartog INDUSTRIES, INC.

Ace Roto-Mold • Injection Molding • Blow Molding • Sowjoy
4010 HOSPERS DRIVE S. BOX 425, HOSPERS, IOWA 51238-0425

DESCRIPTION 1250 GALLON LOW PROFILE SINGLE COMPARTMENT SEPTIC TANK ASSEMBLY AS SHIPPED	
SCALE N.S.	SHEET 1 OF 2
PART NO. LPS-1250-1	

Copyright. All information furnished within this document, electronic file or design correspondence is the property of Den Hartog Industries, Inc. and shall not be used, disclosed to others or copied without the expressed written consent of Den Hartog Industries, Inc.

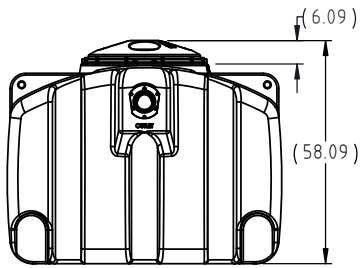

OPTIONAL
BURIAL LID ASSEMBLY
P.N.= ACT-16053BK
SHOWN

LID/COVER OPTIONS.
(TWO COMPLETE COVERS
REQUIRED FOR INSTALLATION).

- 1.) BURIAL LID ASSEMBLY
P.N.=ACT-16053BK
- 2.) 16" GROUND ACCESS RISER
P.N.=ACT-16054BK
- 3.) 28" GROUND ACCESS RISER
P.N.=ACT-16052BK
- 4.) 7" EXTENSION (REQUIRES RISER)
P.N.=AST19365
- 5.) 16" EXTENSION (REQUIRES RISER)
P.N.=AST19212

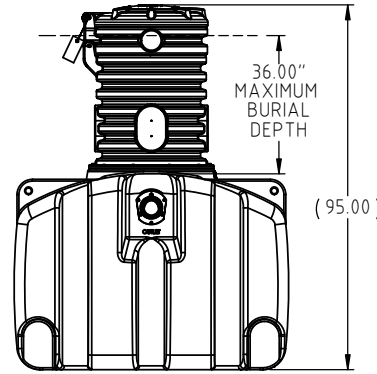

OPTIONAL
28" GROUND ACCESS RISER (ACT-16052BK)
AND 7" EXTENSION (AST19365)
SHOWN

KEY	PART NUMBER	DESCRIPTION	QTY.
1	LPS-1250	1250 GAL LOW PROFILE SEPTIC TANK	1
2	AST19153	CLAMP, STABILIZER	2
3	10087	BOLT, 1/4" X 3/4" HEX GR5 ZINC	6
4	10626	WASHER, 1/4" FLAT ZINC	6
5	14682	PIPE, 4" SEPTIC/CISTERN SUPPORT PVC	4
6	19465	ACT, CISTERN SHIPPING COVER	2
7	SJ10937	WASHER, 3/8" FLAT ZINC	4
8	10089	BOLT, 3/8" X 1" HEX GR 5 ZINC	4
9	14676	LABEL, CAUTION SEPTIC	1

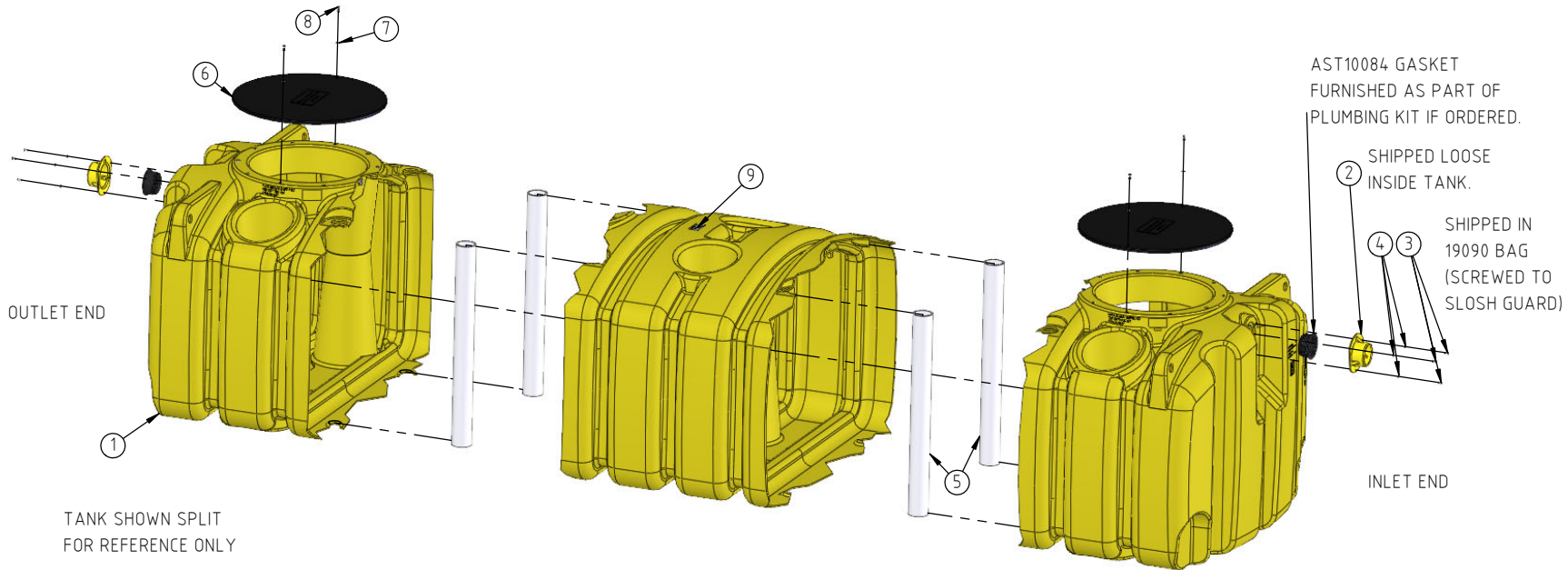

AST10084 GASKET
FURNISHED AS PART OF
PLUMBING KIT IF ORDERED.

SHIPPED LOOSE
INSIDE TANK.

SHIPPED IN
19090 BAG
(SCREWED TO
SLOSH GUARD)

OUTLET END

INLET END

TANK SHOWN SPLIT
FOR REFERENCE ONLY

REV.	DESCRIPTION	BY	DATE	CCN	DRAWN / DATE ADH 12/2/2016	MATERIAL :
					APPRD. / DATE REH 9/8/2017	
ALL DIMENSIONS ARE IN DECIMAL INCHES TOLERANCES UNLESS OTHERWISE SPECIFIED		THIRD ANGLE PROJECTION ANSI 14.5M			SHOT WEIGHT:	NOTES:
POLYETHYLENE		METAL			SHIPPING WEIGHT:	
±1% @ 68°F		DECIMAL ± .125" FRACTION ± 1/4" ANGLE ± 1°			FINISH:	



**Den Hartog
INDUSTRIES, INC.**

Ace Roto-Mold • Injection Molding • Blow Molding • Sowjoy
4010 HOSPERS DRIVE S. BOX 425, HOSPERS, IOWA 51238-0425

DESCRIPTION 1250 GALLON LOW PROFILE SINGLE COMPARTMENT SEPTIC
TANK ASSEMBLY AS SHIPPED

SCALE N.S.	PART NO. LPS-1250-1	SHEET. 2 OF 2
---------------	------------------------	------------------