

Copyright. All information furnished within this document, electronic file or design correspondence is the property of Den Hartog Industries, Inc. and shall not be used, disclosed to others or copied without the expressed written consent of Den Hartog Industries, Inc.

CAUTION LABEL 14676

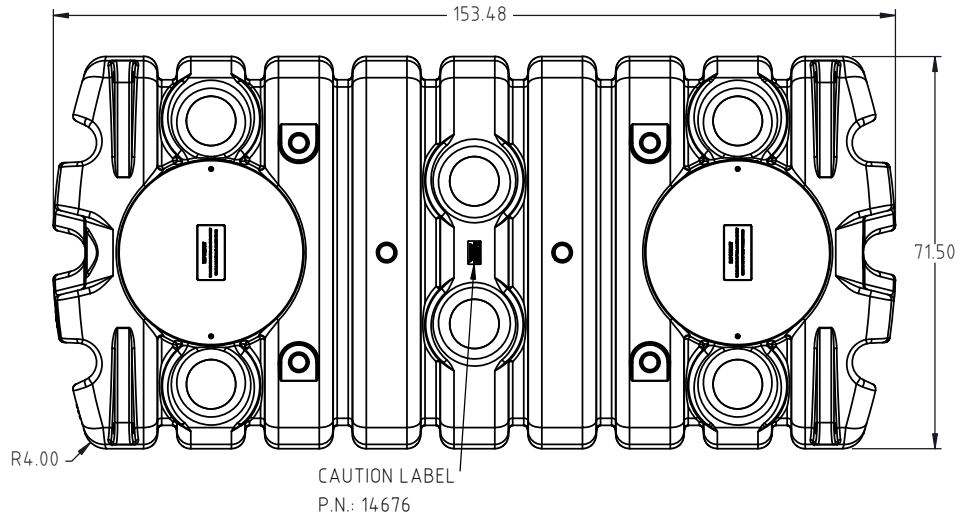

STANDARD TANK SENT WITH TWO 19465 SHIPPING COVERS BUT BURIAL LID(S) AND/OR RISER(S) REQUIRED FOR FINAL INSTALLATION.

BOLT, 3/8" X 1" HEX GR 5 ZINC
P.N.: 10089
X 4

WASHER, 3/8" FLAT ZINC
P.N.: SJ10937
X 4

INSTALLED 4" PVC SUPPORTS
P.N.: 14682
X 2

INSTALLED DIVIDERS
P.N.: 14615 & 14616
X 2 (EACH)

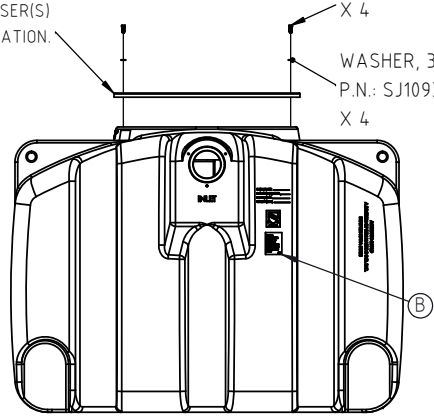

UPC SYMBOL MOLD ON GRAPHIC
P.N. 11331
A
INLET SIDE

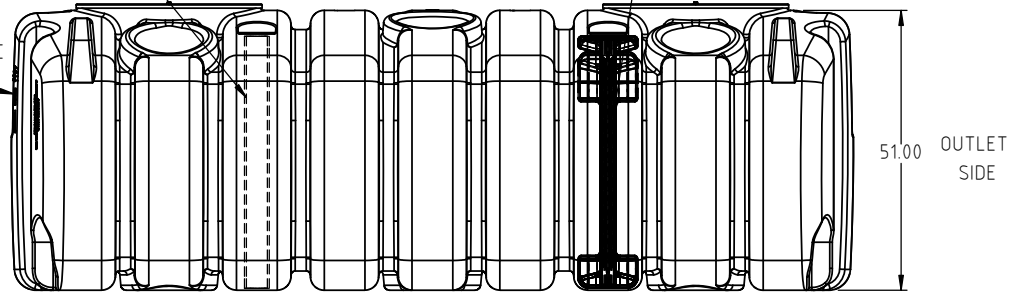

| | | | | |
|--|--|--------------------------------------|-----------|------|
| B | MOLDED IN INFORMATION REMOVED FROM PRINT. 15269 ADDED. | ADH | 1/11/2022 | 4229 |
| A | 11331 NOTE ADDED TO THE PRINT. | ADH | 5/7/2018 | 3553 |
| REV. | DESCRIPTION | BY | DATE | CCN |
| ALL DIMENSIONS ARE IN DECIMAL INCHES TOLERANCES UNLESS OTHERWISE SPECIFIED | | THIRD ANGLE PROJECTION ANSI 14.5M | | |
| POLYETHYLENE ±1% @ 68°F | | | | |
| METAL DECIMAL ± .125" FRACTION ± 1/4" ANGLE ± 1° | | | | |

| | |
|--------------------------------|------------|
| DRAWN / DATE ADH 12/2/2016 | MATERIAL : |
| APPRD. / DATE REH 9/11/2017 | |
| SHOT WEIGHT: | NOTES: |
| SHIPPING WEIGHT: 714.00 LBS. | |
| FINISH: | |

Den Hartog INDUSTRIES, INC.

Ace Roto-Mold • Injection Molding • Blow Molding • Sowjoy
4010 HOSPERS DRIVE S. BOX 425, HOSPERS, IOWA 51238-0425

| | |
|---|---------------------|
| DESCRIPTION 1500 GALLON LOW PROFILE TWO COMPARTMENT SEPTIC TANK ASSEMBLY AS SHIPPED | |
| SCALE N.S. | PART NO. LPS-1500-2 |
| SHEET 1 OF 2 | |

Copyright. All information furnished within this document, electronic file or design correspondence is the property of Den Hartog Industries, Inc. and shall not be used, disclosed to others or copied without the expressed written consent of Den Hartog Industries, Inc.

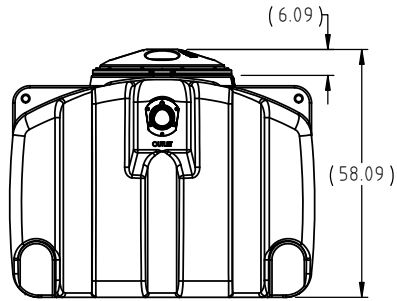

OPTIONAL
BURIAL LID ASSEMBLY
P.N.= ACT-16053BK
SHOWN

LID/COVER OPTIONS.
(TWO COMPLETE COVERS
REQUIRED FOR INSTALLATION).

- 1.) BURIAL LID ASSEMBLY
P.N.=ACT-16053BK
- 2.) 16" GROUND ACCESS RISER
P.N.=ACT-16054BK
- 3.) 28" GROUND ACCESS RISER
P.N.=ACT-16052BK
- 4.) 7" EXTENSION (REQUIRES RISER)
P.N.=AST19365
- 5.) 16" EXTENSION (REQUIRES RISER)
P.N.=AST19212

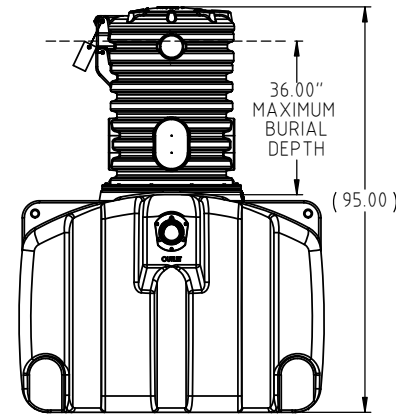

OPTIONAL
28" GROUND ACCESS RISER (ACT-16052BK)
AND 7" EXTENSION (AST19365)
SHOWN

| KEY | PART NUMBER | DESCRIPTION | QTY. |
|-----|-------------|-------------------------------------|------|
| 1 | LPS-1500 | 1500 GAL LOW PROFILE SEPTIC TANK | 1 |
| 2 | 14616 | OUTER DIVIDER | 2 |
| 3 | 14615 | INNER DIVIDER | 2 |
| 4 | AST19153 | CLAMP, STABILIZER | 2 |
| 5 | 10087 | BOLT, 1/4" X 3/4" HEX GR5 ZINC | 6 |
| 6 | 10626 | WASHER, 1/4" FLAT ZINC | 6 |
| 7 | 14682 | PIPE, 4" SEPTIC/CISTERN SUPPORT PVC | 2 |
| 8 | 19465 | ACT, CISTERN SHIPPING COVER | 2 |
| 9 | SJ10937 | WASHER, 3/8" FLAT ZINC | 8 |
| 10 | 10089 | BOLT, 3/8" X 1" HEX GR 5 ZINC | 4 |
| 11 | 14676 | LABEL, CAUTION SEPTIC | 1 |
| 12 | 10007 | BOLT, 3/8" X 2" HEX GR 5 ZINC | 4 |
| 13 | 15269 | LABEL, 1500 GAL LPS | 1 |

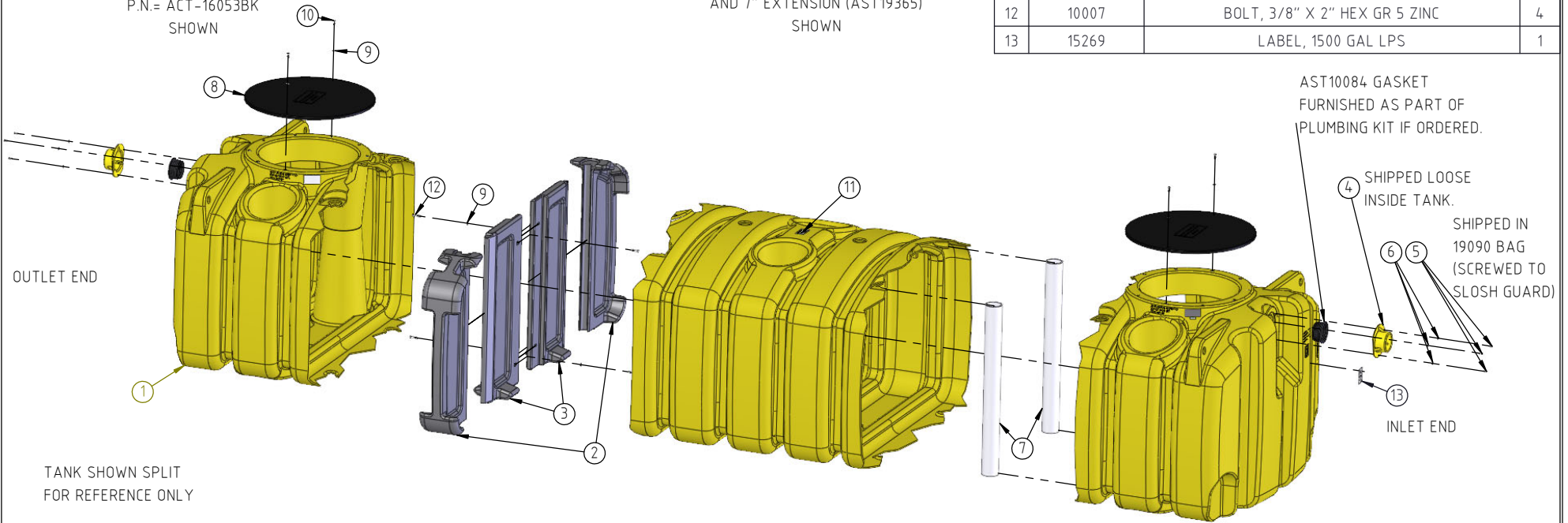

TANK SHOWN SPLIT
FOR REFERENCE ONLY

| | | | | | | | |
|---|--------------------------------------|-----------------|------------------|-----------------|---------------|----------------|---------------|
| REV. | DESCRIPTION | BY | DATE | CCN | DRAWN / DATE | MATERIAL : | |
| | | | | | ADH 12/2/2016 | | |
| ALL DIMENSIONS ARE IN DECIMAL INCHES TOLERANCES UNLESS OTHERWISE SPECIFIED | THIRD ANGLE PROJECTION ANSI 14.5M | SHOT WEIGHT: | SHIPPING WEIGHT: | FINISH: | NOTES: | APPROD. / DATE | |
| | | | | | | | REH 9/11/2017 |
| POLYETHYLENE | METAL | DECIMAL ± .125" | | FRACTION ± 1/4" | | ANGLE ± 1° | |
| ±1% @ 68°F | | | | | | | |



**Den Hartog
INDUSTRIES, INC.**

Ace Roto-Mold • Injection Molding • Blow Molding • Sowjoy
4010 HOSPERS DRIVE S. BOX 425, HOSPERS, IOWA 51238-0425

| | | |
|-------------|--|---------------------|
| DESCRIPTION | 1500 GALLON LOW PROFILE TWO COMPARTMENT SEPTIC TANK ASSEMBLY AS SHIPPED | |
| SCALE | N.S. | PART NO. LPS-1500-2 |
| SHEET. | 2 OF 2 | |