

Copyright. All information furnished within this document, electronic file or design correspondence is the property of Den Hartog Industries, Inc. and shall not be used, disclosed to others or copied without the expressed written consent of Den Hartog Industries, Inc.

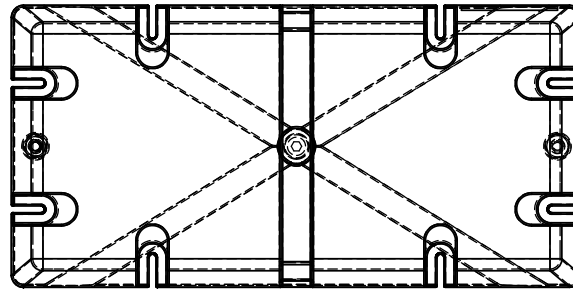

NOTE: BUOYANCY IS 756 LBS.(343 KG)

				DRAWN / DATE ADH 4/11/19	MATERIAL POLYETHYLENE
				APPRD. / DATE REH 7/15/19	
REV	DESCRIPTION	BY / DATE	CCN		
ALL DIMENSIONS ARE IN DECIMAL INCHES TOLERANCES UNLESS OTHERWISE SPECIFIED		THIRD ANGLE PROJECTION ANSI 14.5M		SHOT WEIGHT: 35 LBS.(15.9 KG.)	NOTES: 1.) AF 35 LBS.(15.9 KG.) 2.) FF 50 LBS.(22.7.) 3.) 0.150 IN (3.81 mm) NOM. WALL
POLYETHYLENE		METAL DECIMAL ± .125" FRACTION ± 1/4" ANGLE ± 1°		SHIPPING WEIGHT: SEE NOTES	
±1% @ 68°F				FINISH:	

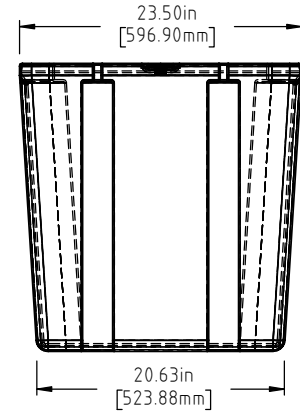
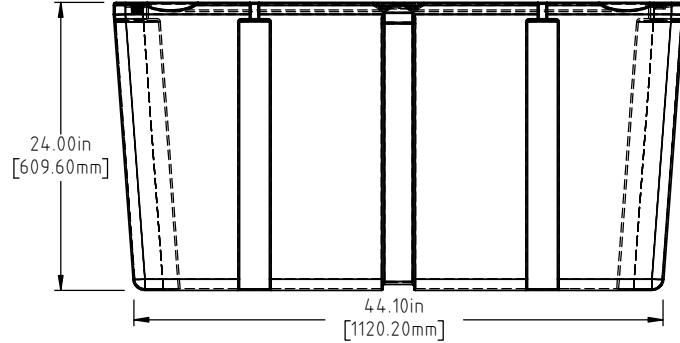
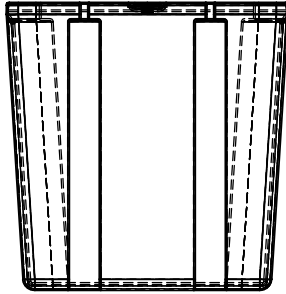
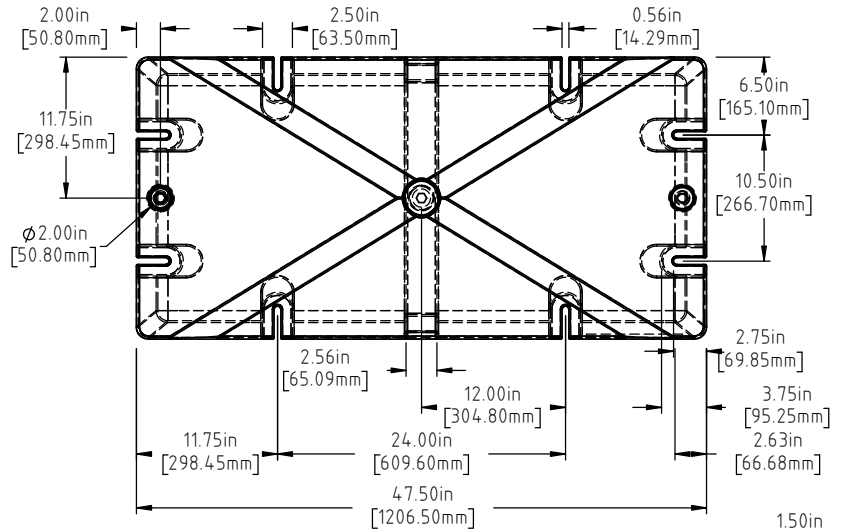

Den Hartog
INDUSTRIES, INC.

Ace Roto-Mold Injection Molding Blow Molding Sowjoy

4010 HOSPERS DRIVE S. BOX 425, HOSPERS, IOWA 51238-0425

DESCRIPTION 24 X 48 X 24 LONG SLOT FLOAT	
SCALE N.S.	PART NO. LS2448-24