

© DEN HARTOG INDUSTRIES, INC.

Copyright. All information furnished within this document, electronic file or design correspondence is the property of Den Hartog industries, Inc. and shall not be used, disclosed to others or copied without the expressed written consent of Den Hartog Industries, Inc.

LS3648-20

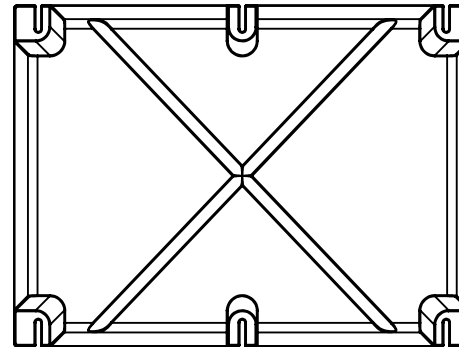
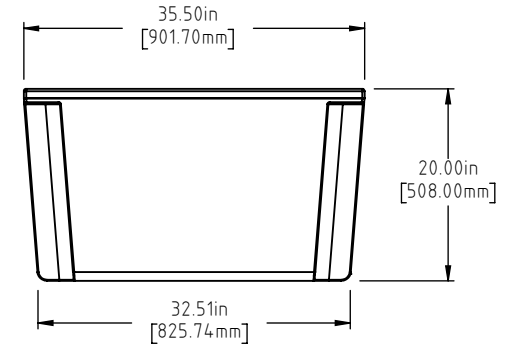
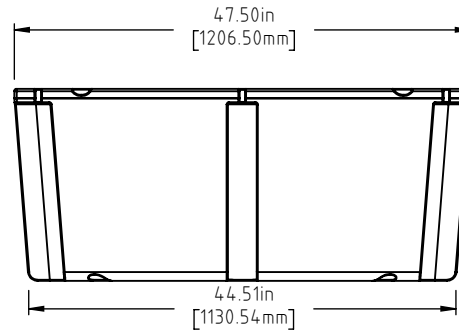
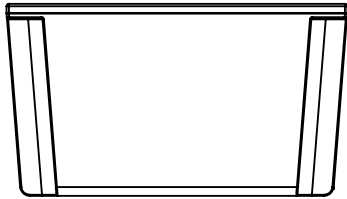
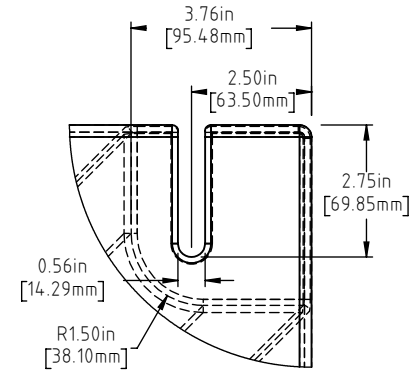
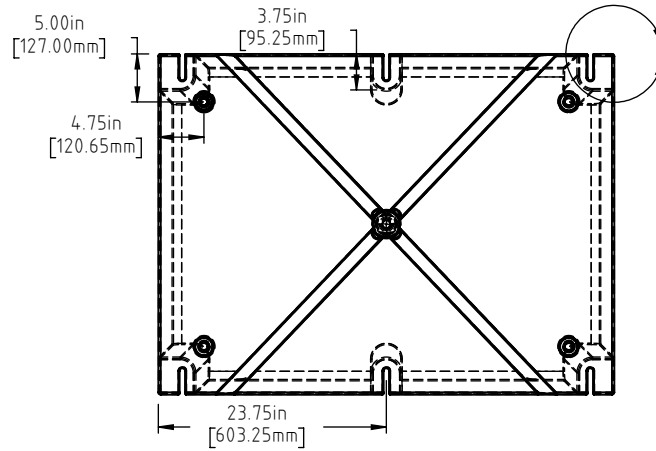

NOTE: BUOYANCY IS 967 LBS.(438.62 KG)

				DRAWN / DATE ADH 3/4/19	MATERIAL POLYETHYLENE
				APPROD. / DATE REH 7/15/19	
REV	DESCRIPTION	BY / DATE	CCN	SHOT WEIGHT: 40 LBS. (18.2KG.)	NOTES: 1.) AF 40 LBS. (18.2 KG.) 2.) FF 62 LBS. (28.2 KG.) 3.) 0.150 IN (3.81 mm) NOM. WALL
	ALL DIMENSIONS ARE IN DECIMAL INCHES TOLERANCES UNLESS OTHERWISE SPECIFIED POLYETHYLENE ±1% @ 68°F			SHIPPING WEIGHT: SEE NOTES	
	METAL DECIMAL ± .125" FRACTION ± 1/4" ANGLE ± 1°	THIRD ANGLE PROJECTION ANSI 14.5M		FINISH:	



Den Hartog
INDUSTRIES, INC.

Ace Roto-Mold Injection Molding Blow Molding Sowjoy

4010 HOSPERS DRIVE S. BOX 425, HOSPERS, IOWA 51238-0425

DESCRIPTION	36 X 48 X 20 FLOAT LONG SLOT	
SCALE	N.S.	PART NO. LS3648-20