

© DEN HARTOG INDUSTRIES, INC.

Copyright. All information furnished within this document, electronic file or design correspondence is the property of Den Hartog Industries, Inc. and shall not be used, disclosed to others or copied without the expressed written consent of Den Hartog Industries, Inc.

LS4872-20

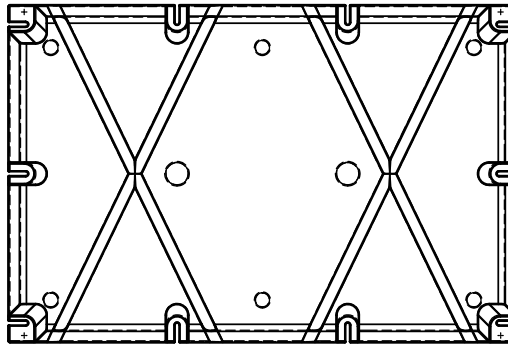
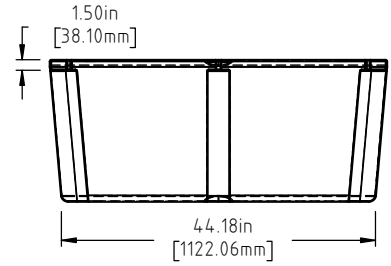
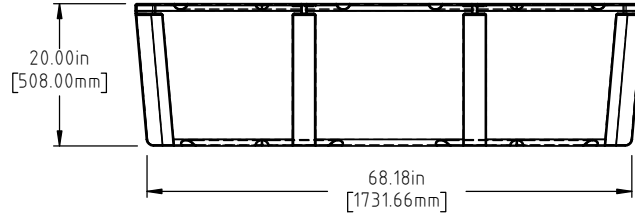
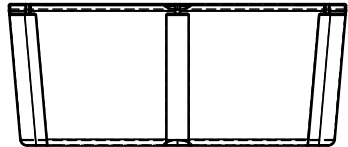
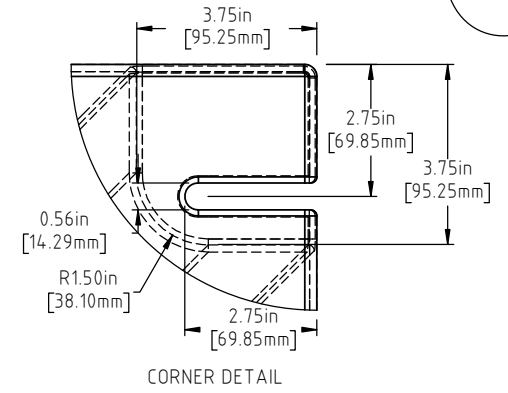
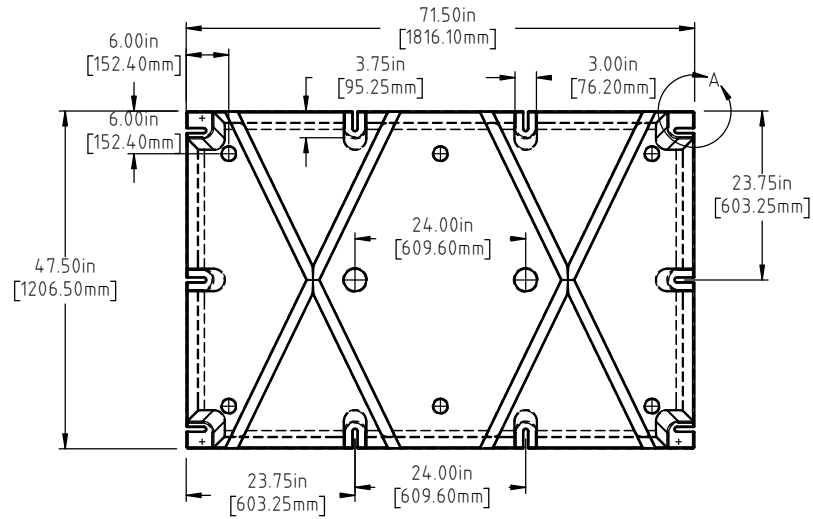

NOTE: BUOYANCY IS 1996 LBS (905.37 KG.)

REV	DESCRIPTION	BY / DATE	CCN	DRAWN / DATE ADH 1/7/20	MATERIAL POLYETHYLENE
				APPRD. / DATE REH 1/29/20	
	ALL DIMENSIONS ARE IN DECIMAL INCHES TOLERANCES UNLESS OTHERWISE SPECIFIED	THIRD ANGLE PROJECTION ANSI 14.5M		SHOT WEIGHT: 61.00 LBS. (27.67 KG)	NOTES: 1.) AF 61.00 LBS (27.67 KG) 2.) FF 96.00 LBS (48.99 KG) 3.) .150IN (3.82mm) NOM. WALL
	POLYETHYLENE			SHIPPING WEIGHT: SEE NOTES	
	±1% @ 68°F			FINISH:	



Den Hartog

INDUSTRIES, INC.

Ace Roto-Mold Injection Molding Blow Molding Sowjoy

4010 HOSPERS DRIVE S. BOX 425, HOSPERS, IOWA 51238-0425

DESCRIPTION	48 X 72 X 20 FLOAT LONG SLOT	
SCALE	N.S.	PART NO. LS4872-20