

Copyright. All information furnished within this document, electronic file or design correspondence is the property of Den Hartog Industries, Inc. and shall not be used, disclosed to others or copied without the expressed written consent of Den Hartog Industries, Inc.

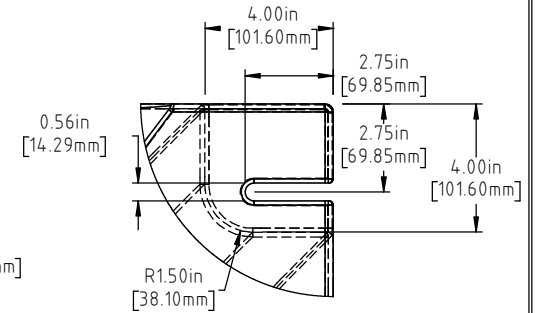

DETAIL A  
SCALE 1: 6

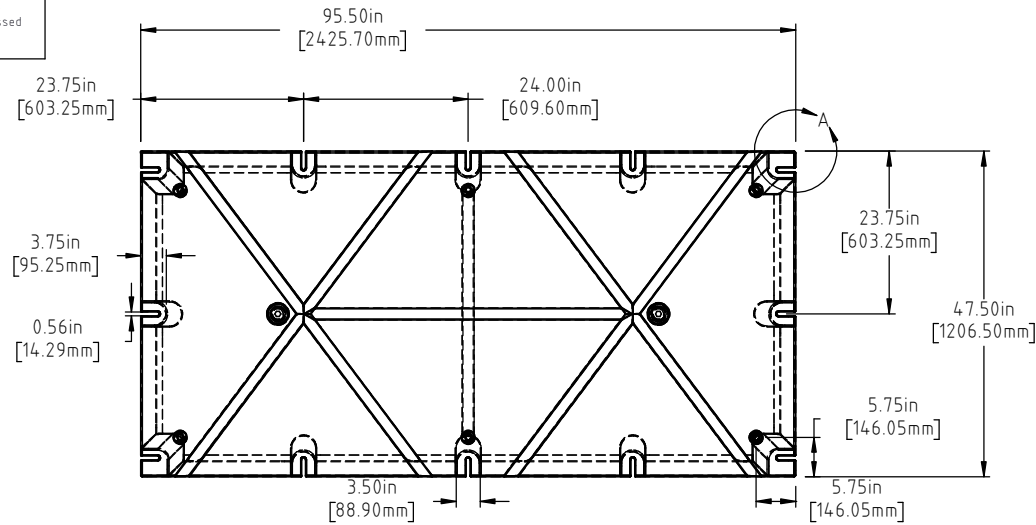
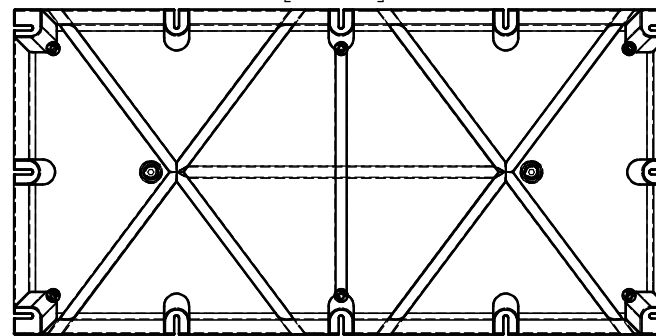
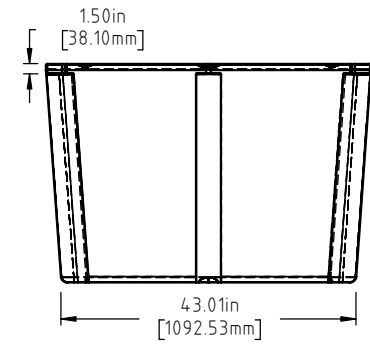
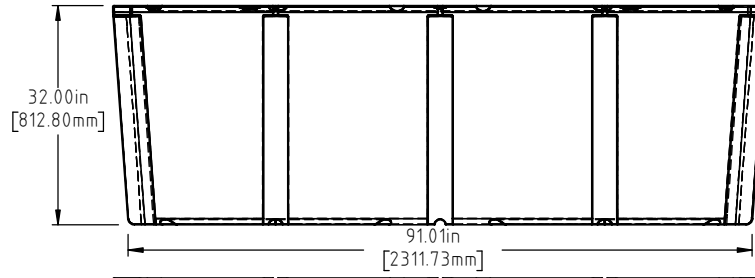
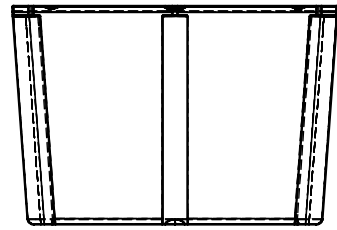

NOTE: BUOYANCY 4438 LBS.(2013.04 KG.)

				DRAWN / DATE ADH 12/26/19	MATERIAL POLYETHYLENE
				APPROD. / DATE REH 3/31/20	
REV	DESCRIPTION	BY / DATE	CCN		
ALL DIMENSIONS ARE IN DECIMAL INCHES TOLERANCES UNLESS OTHERWISE SPECIFIED		THIRD ANGLE PROJECTION ANSI 14.5M		SHOT WEIGHT: 98 LBS.(44.5 KG.)	NOTES: 1.) AF 98 LBS.(44.5 KG.) 2.) FF 193 LBS.(87.5 KG) 3.) 0.150in(3.81mm) NOM. WALL
POLYETHYLENE		METAL DECIMAL ± .125" FRACTION ± 1/4" ANGLE ± 1°		SHIPPING WEIGHT: SEE NOTES	
±1% @ 68°F				FINISH:	



**Den Hartog**  
INDUSTRIES, INC.

Ace Roto-Mold Injection Molding Blow Molding Sowjoy

4010 HOSPERS DRIVE S. BOX 425, HOSPERS, IOWA 51238-0425

DESCRIPTION 48 X 96 X 32 FLOAT-LONG SLOT	
SCALE N.S.	PART NO. LS4896-32