

PROPRIETARY DATA

INFORMATION FURNISHED HEREIN IS THE PROPERTY OF DEN HARTOG INDUSTRIES INC. AND SHALL NOT BE USED, DISCLOSED TO OTHERS, OR COPIED WITHOUT EXPRESSED WRITTEN CONSENT OF DEN HARTOG IND. ALL RIGHTS RESERVED.

OP0325-RT

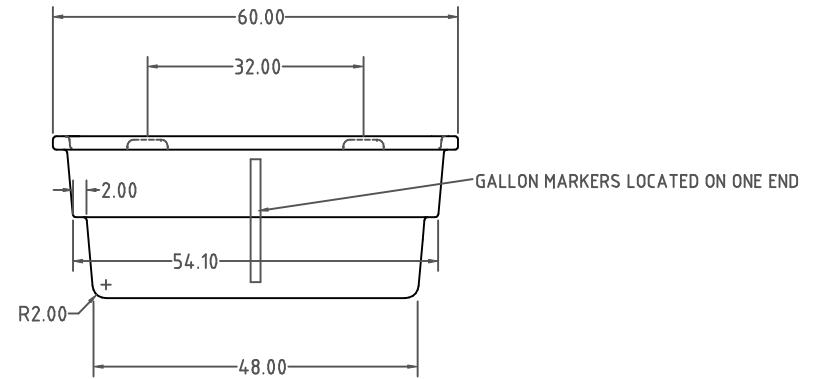
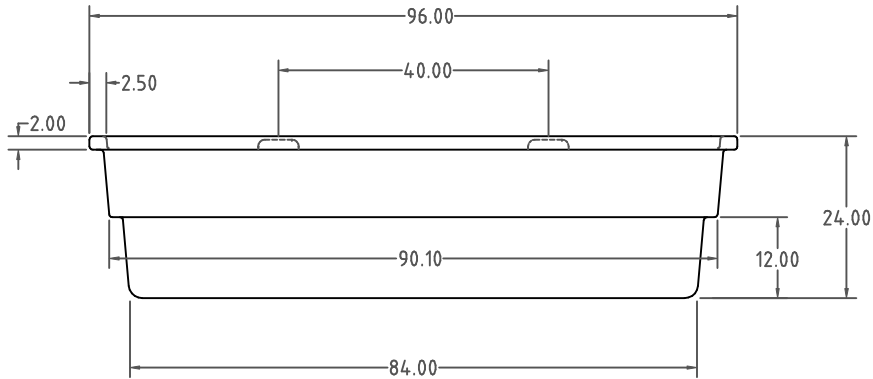
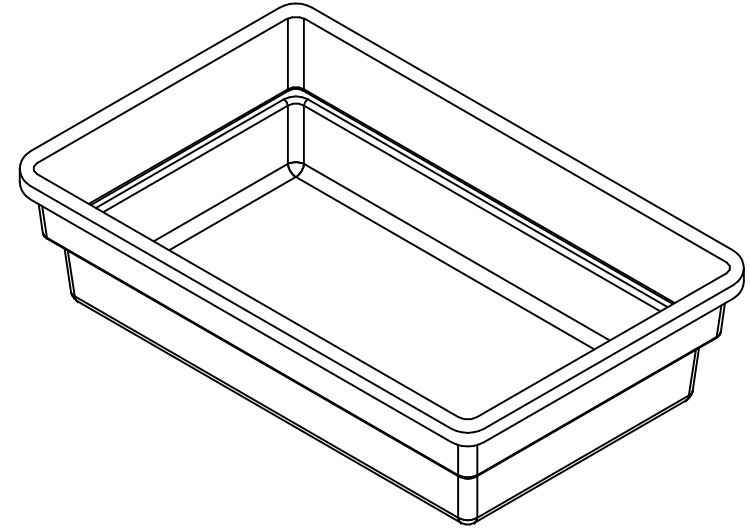
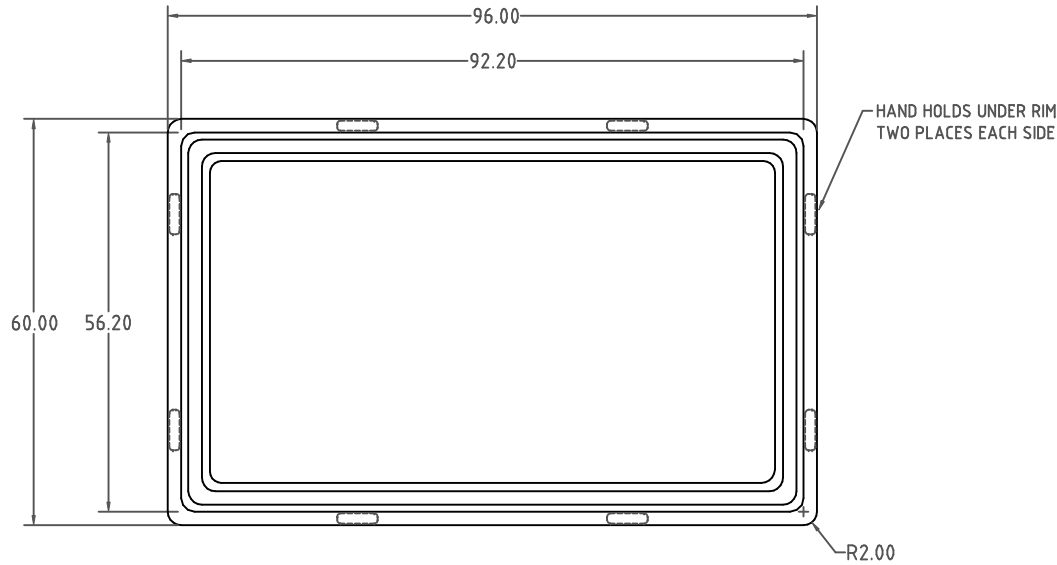

DRAWN /DATE

DHJ 10/3/07

MATERIAL

SHOT WEIGHT = 115 LBS. = .25 WALL
10538 2 MELT NATURAL RESIN



Ace Roto-Mold

A DIVISION OF DEN HARTOG INDUSTRIES, INC.
4010 HOSPERS DRIVE SOUTH, BOX 425, HOSPERS, IOWA 51238

REV	DESCRIPTION	DATE APPRD.	CCN

APPRD. /DATE
REH 11/9/07

CLIENT / DESCRIPTION

325 GALLON CONTAINMENT TANK

ALL DIMENSIONS ARE IN DECIMAL INCHES
TOLERANCES UNLESS OTHERWISE SPECIFIED

THIRD ANGLE PROJECTION
ANSI 14.5M

NOTES:

SCALE
NONE

PART NO.
OP0325-RT

± 1 % @ 68°F

