

**PROPRIETARY DATA**

INFORMATION FURNISHED HEREIN IS THE PROPERTY OF DEN HARTOG INDUSTRIES INC. AND SHALL NOT BE USED, DISCLOSED TO OTHERS, OR COPIED WITHOUT EXPRESSED WRITTEN CONSENT OF DEN HARTOG IND. ALL RIGHTS RESERVED.

OP0625-RT

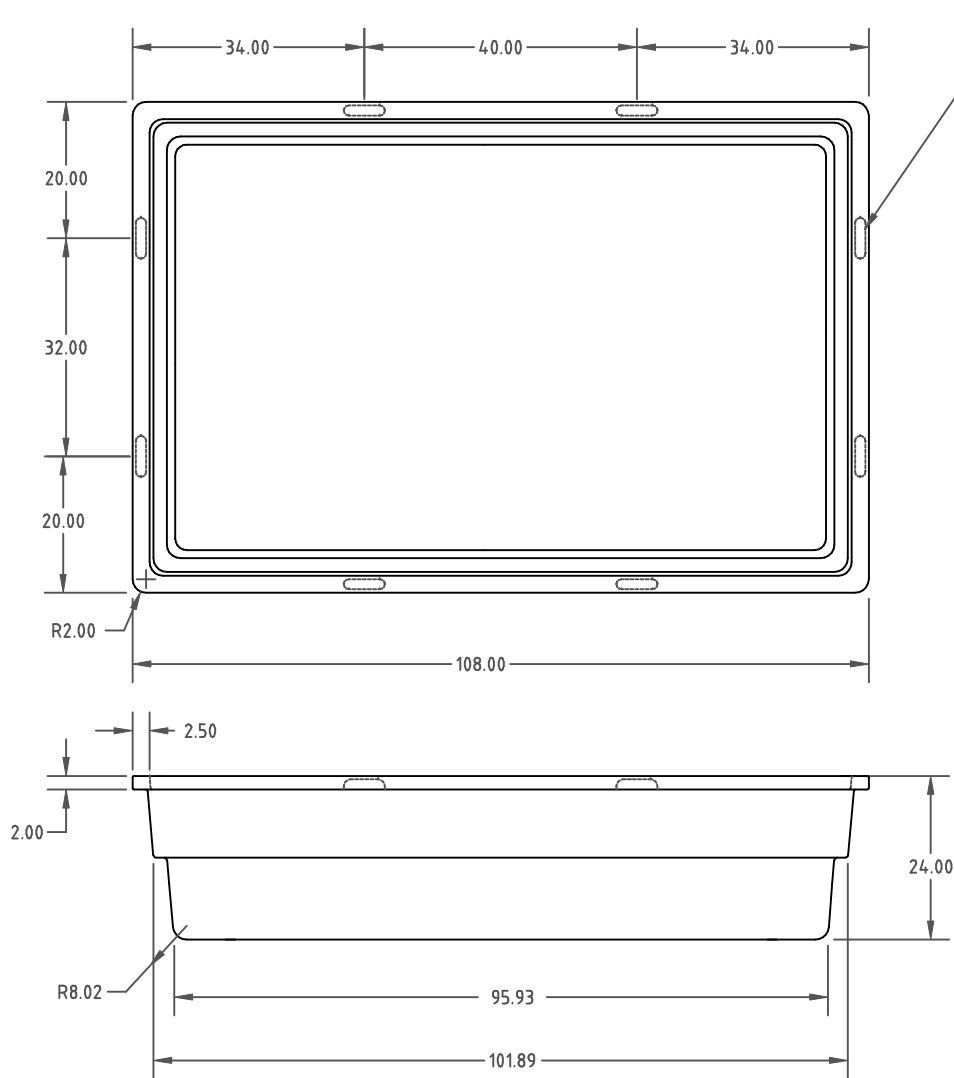

HAND HOLDS UNDER RIM  
TWO PLACES EACH SIDE

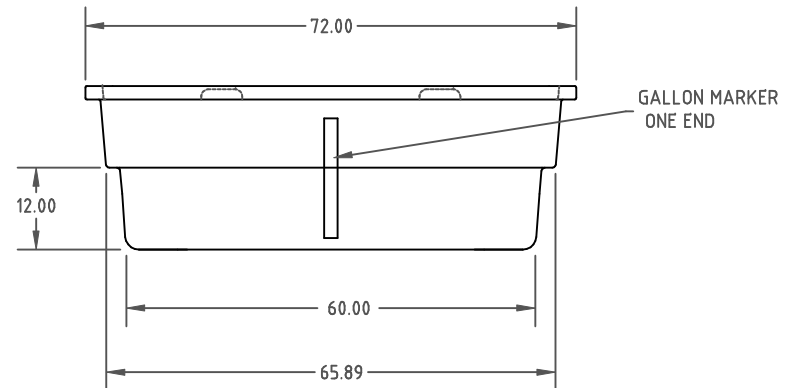
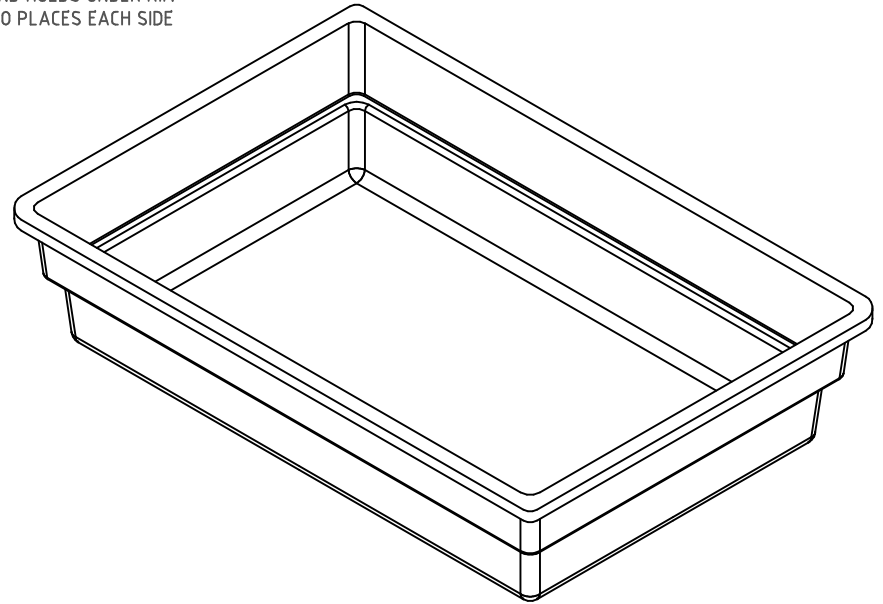

				DRAWN /DATE DHJ 2/5/08	MATERIAL
				APPRD. /DATE REH 6/25/08	SHOT WEIGHT = 145 LBS. = .25 WALL 10538 2 MELT NATURAL RESIN
REV	DESCRIPTION	DATE APPRD.	CCN		
ALL DIMENSIONS ARE IN DECIMAL INCHES TOLERANCES UNLESS OTHERWISE SPECIFIED ± 1 % @ 68°F				THIRD ANGLE PROJECTION ANSI 14.5M 	NOTES :

 **Ace Roto-Mold**  
 A DIVISION OF DEN HARTOG INDUSTRIES, INC.  
 4010 HOSPERS DRIVE SOUTH, BOX 425, HOSPERS, IOWA 51238

CLIENT / DESCRIPTION  
**625 GALLON CONTAINMENT TANK**

SCALE NONE      PART NO. **OP0625-RT**