

Copyright. All information furnished within this document, electronic file or design correspondence is the property of Den Hartog industries, Inc. and shall not be used, disclosed to others or copied without the expressed written consent of Den Hartog Industries, Inc.

LID TRIM AND FASTENING DETAIL

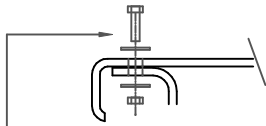

3/8" X 1-1/2" HEX BOLT, 3/8" FLATWASHERS AND HEX NUT 12 PLACES

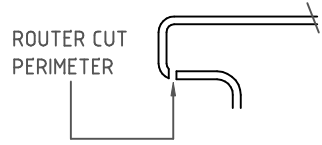
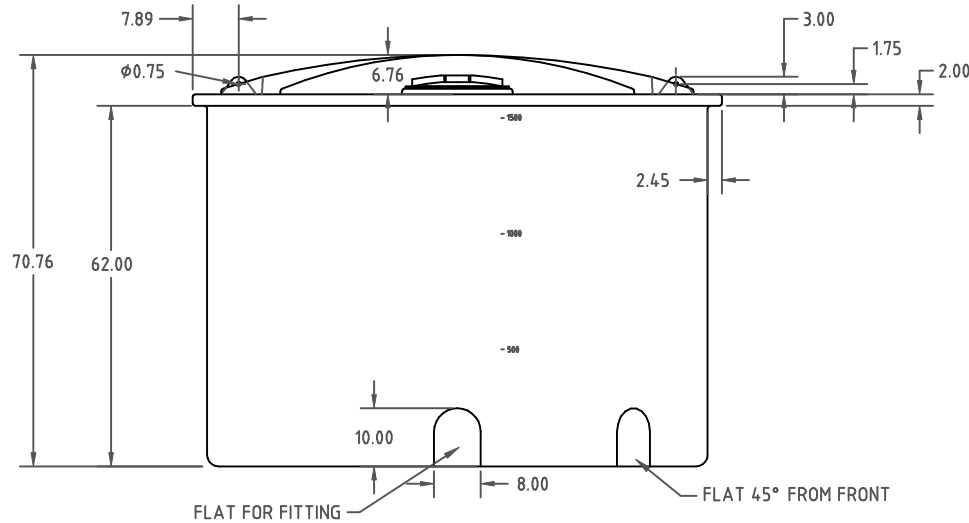
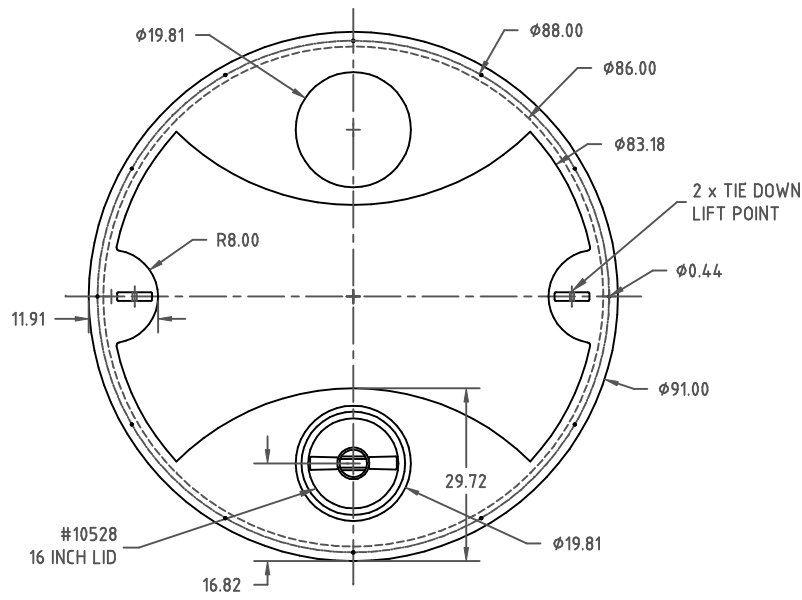

REV	DESCRIPTION	BY / DATE	CCN
ALL DIMENSIONS ARE IN DECIMAL INCHES TOLERANCES UNLESS OTHERWISE SPECIFIED			
POLYETHYLENE		METAL DECIMAL $\pm .125"$ FRACTION $\pm 1/4"$ ANGLE $\pm 1^\circ$	
THIRD ANGLE PROJECTION ANSI 14.5M			

DRAWN / DATE DHJ 4/29/11	MATERIAL 10420
APPRD. / DATE REH 5/10/11	
SHOT WEIGHT: 250 LBS.	NOTES: 1. .270 THICK AT FITTING
SHIPPING WEIGHT: 252 LBS.	
FINISH:	

Den Hartog

INDUSTRIES, INC.

Ace Roto-Mold Injection Molding Blow Molding Sowjoy
4010 HOSPERS DRIVE S. BOX 425, HOSPERS, IOWA 51238-0425

DESCRIPTION		1510 GALLON OPEN TOP TANK	
SCALE	N.S.	PART NO.	OP1510-86