

Copyright. All information furnished within this document, electronic file or design correspondence is the property of Den Hartog industries, Inc. and shall not be used, disclosed to others or copied without the expressed written consent of Den Hartog Industries, Inc.

LID TRIM AND FASTENING DETAIL

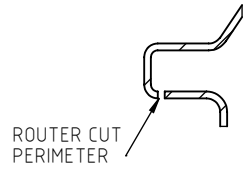

ROUTER CUT PERIMETER

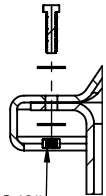

3/8" X 1-1/2" HEX BOLT, 3/8" FLAT WASHERS AND HEX NUT 12 PLACES

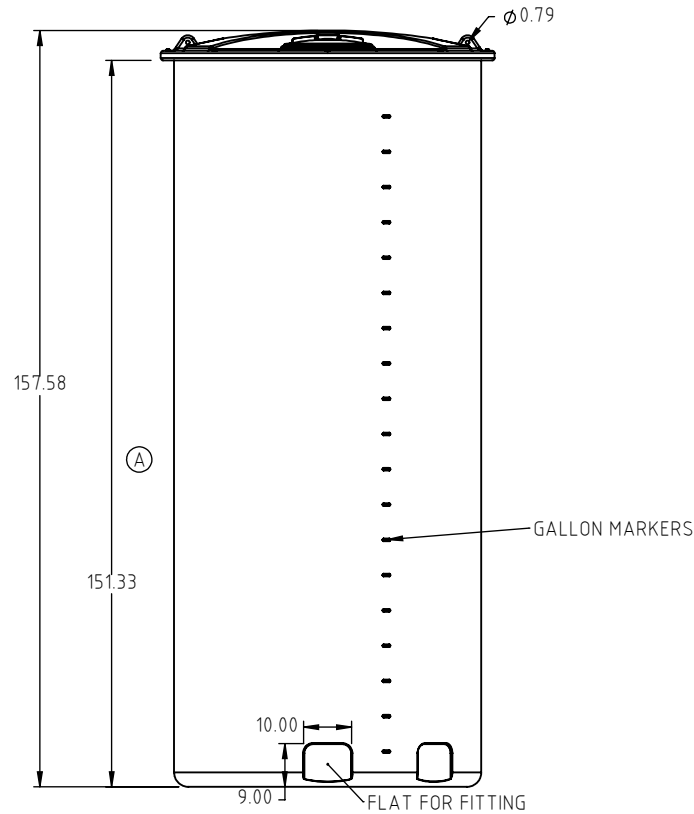
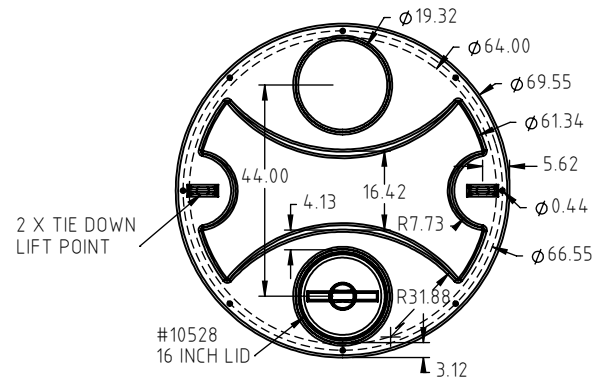

B	UPDATED PRINT PART NUMBER	NHW 1/15/21	4082	DRAWN / DATE	DHJ 2/2/12	MATERIAL	10420
A	RIBS REMOVED	ADH 10/9/18	3650	APPRO. / DATE	REH 3/6/12		
REV	DESCRIPTION	BY / DATE	CCN				
ALL DIMENSIONS ARE IN DECIMAL INCHES TOLERANCES UNLESS OTHERWISE SPECIFIED		THIRD ANGLE PROJECTION ANSI 14.5M		SHOT WEIGHT:	463.00 LBS	NOTES:	1.) 0.49" WALL
POLYETHYLENE		METAL		SHIPPING WEIGHT:	465.00 LBS		
$\pm 1\%$ @ 68°F		DECIMAL $\pm .125"$ FRACTION $\pm 1/4"$ ANGLE $\pm 1^\circ$					



Den Hartog
INDUSTRIES, INC.

Ace Roto-Mold Injection Molding Blow Molding Sowjoy

4010 HOSPERS DRIVE S. BOX 425, HOSPERS, IOWA 51238-0425

DESCRIPTION 2010 GALLON OPEN TOP WITH BOLT ON TOP

SCALE N.S.

PART NO. OP2010-64 (B)