

Copyright. All information furnished within this document, electronic file or design correspondence is the property of Den Hartog Industries, Inc. and shall not be used, disclosed to others or copied without the expressed written consent of Den Hartog Industries, Inc.

PC0100-SBPS 2 PER SET

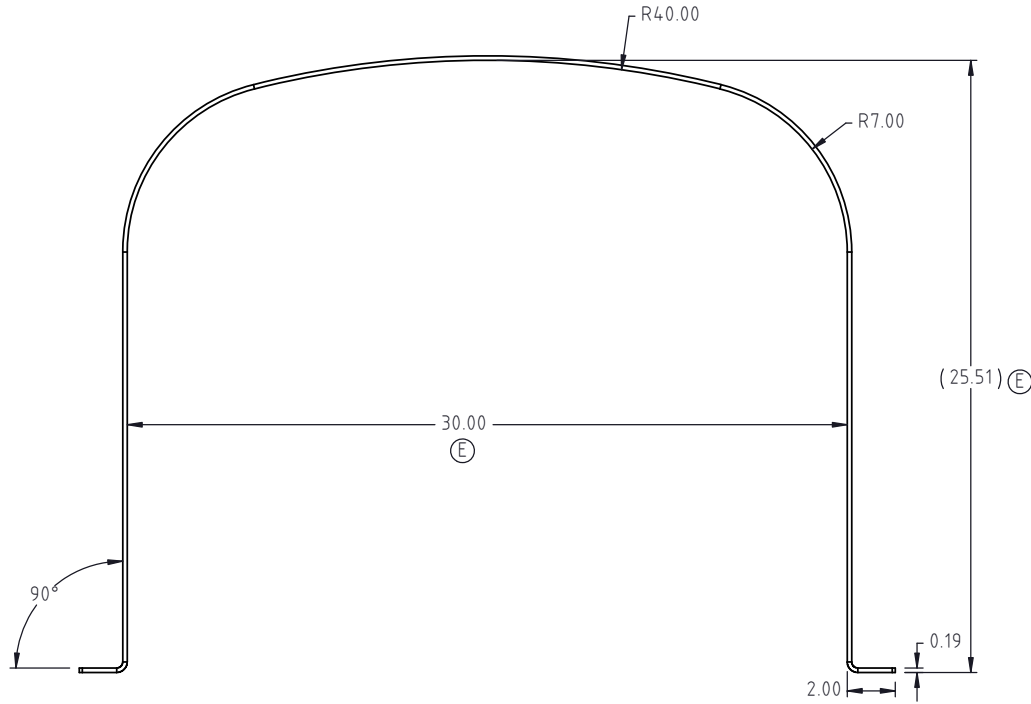
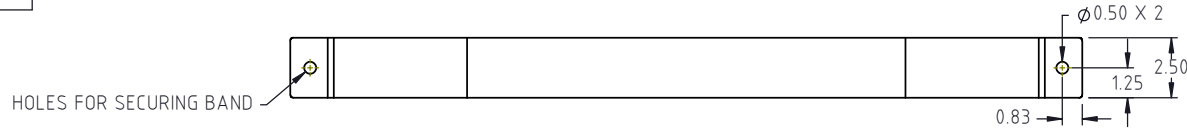

BANDS ARE PRESENT IN ORDER TO FIT SNUGLY AROUND TANK (MAY NOT APPEAR IN U SHAPE AS SHOWN HERE)

E	30.00" WAS 29.00", 76.8" CORRECTED FROM 72.00". HEIGHT REFERENCE ADDED TO PRINT.	ADH	6/16/2025	4746	DRAWN / DATE	MATERIAL :
D	REMOVED SILVER COLOR	GPI	8/13/2021	4164	NVE 6/27/2005	SHEET, 3/16" MILD STEEL A36
C	WEIGHT AND DIMENSION ADDED, DRAWING TEMPLATE UPDATED	ADH	12/2/2019	1978	APPRD. / DATE	
REV.	DESCRIPTION	BY	DATE	CCN	DHJ 9/21/2005	
ALL DIMENSIONS ARE IN DECIMAL INCHES TOLERANCES UNLESS OTHERWISE SPECIFIED		THIRD ANGLE PROJECTION ANSI 14.5M		SHOT WEIGHT:		NOTES: (E) 1.) BLANK LENGTH: 76.8"
POLYETHYLENE		METAL		SHIPPING WEIGHT: 10 LBS.		
±1% @ 68°F		DECIMAL ± .125" FRACTION ± 1/4" ANGLE ± 1°		FINISH: POWDER COAT, BLACK TILE, 40012		



Den Hartog INDUSTRIES, INC.

Ace Roto-Mold • Injection Molding • Blow Molding • Sowjoy
4010 HOSPERS DRIVE S. BOX 425, HOSPERS, IOWA 51238-0425

DESCRIPTION 100 GALLON POWDER COATED STEEL BAND FOR PCO TANKS		
SCALE N.S.	PART NO. PC0100-SBPS	SHEET 1 OF 1