

© DEN HARTOG INDUSTRIES, INC.

Copyright. All information furnished within this document, electronic file or design correspondence is the property of Den Hartog Industries, Inc. and shall not be used, disclosed to others or copied without the expressed written consent of Den Hartog Industries, Inc.

KEY	PART NUMBER	DESCRIPTION	QTY.
1	SJ15500	SUPPORT, END BAR	2
2	SJ15501	SUPPORT, END 1/4" X 1/2" FLAT	2
3	SJ15502	SUPPORT, CROSS	3
4	SJ15503	SUPPORT, TAB 3-3/8"	2
5	SJ15504	SUPPORT, TAB 3-3/4"	2
6	SJ15505	SUPPORT, TAB 4"	2
7	SJ16008	SUPPORT BAR, SIDE (FS-NUR)	2

SJFPS001

A

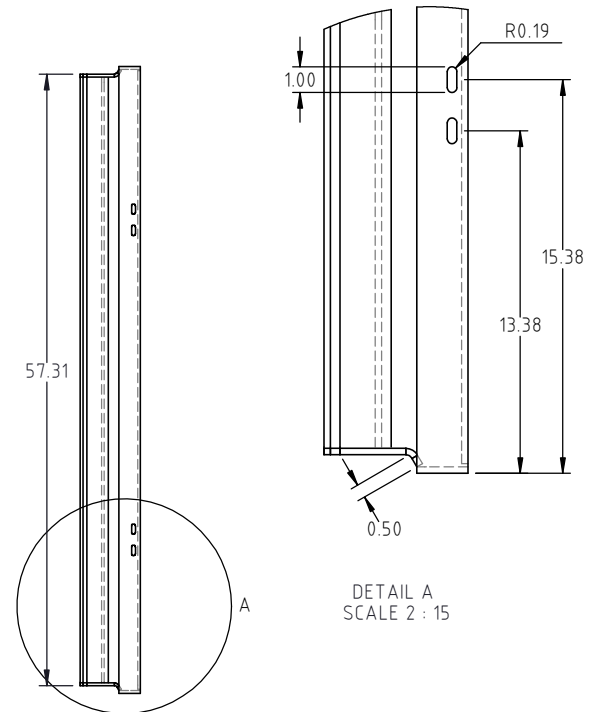
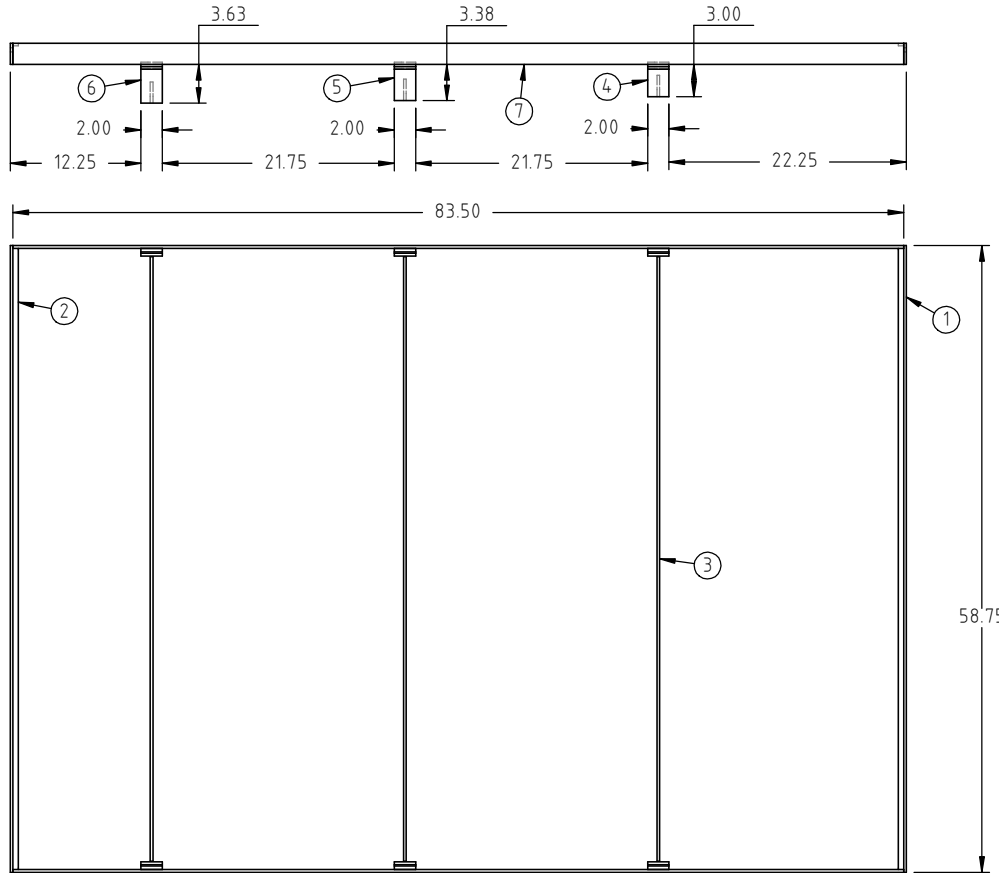

DETAIL A  
SCALE 2 : 15

				DRAWN / DATE ADH 8/4/09	MATERIAL
A	SJ15503 END VIEWS UPDATED.	ADH 5/2/16	3246	APPROD. / DATE KGJ 4/27/10	
REV	DESCRIPTION	BY / DATE	CCN		
ALL DIMENSIONS ARE IN DECIMAL INCHES TOLERANCES UNLESS OTHERWISE SPECIFIED		THIRD ANGLE PROJECTION ANSI 14.5M		SHOT WEIGHT:	NOTES:
POLYETHYLENE		METAL DECIMAL ± .125" FRACTION ± 1/4" ANGLE ± 1°		SHIPPING WEIGHT: 72 LBS	
±1% @ 68°F		FINISH: RECLAIM POWDER COAT			



**Den Hartog**  
INDUSTRIES, INC.

Ace Roto-Mold Injection Molding Blow Molding Sowjoy

4010 HOSPERS DRIVE S. BOX 425, HOSPERS, IOWA 51238-0421

DESCRIPTION FLUSH PAN SUPPORT FRAME	
SCALE N.S.	PART NO. SJFPS001

Copyright. All information furnished within this document, electronic file or design correspondence is the property of Den Hartog industries, Inc. and shall not be used, disclosed to others or copied without the expressed written consent of Den Hartog Industries, Inc.

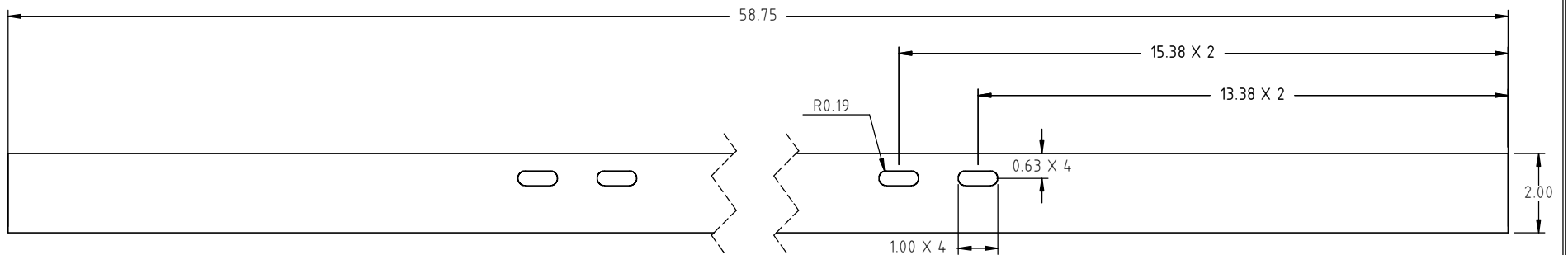

				DRAWN / DATE ADH 8/10/09	MATERIAL 1.) FLAT, 1/4" X 2" MILD STEEL
A	.062" WAS .125"	ADH 5/2/16	3246	APPRD. / DATE	2.) SHEER FROM B02500X20000
REV	DESCRIPTION	BY / DATE	CCN	KGJ 4/27/10	
ALL DIMENSIONS ARE IN DECIMAL INCHES TOLERANCES UNLESS OTHERWISE SPECIFIED		THIRD ANGLE PROJECTION ANSI 14.5M		SHOT WEIGHT:	NOTES:
POLYETHYLENE		METAL DECIMAL ± .062" (A) FRACTION ± 1/4" ANGLE ± 1°		SHIPPING WEIGHT:	
±1% @ 68°F				FINISH:	



**Den Hartog**  
INDUSTRIES, INC.

Ace Roto-Mold Injection Molding Blow Molding Sowjoy

4010 HOSPERS DRIVE S. BOX 425, HOSPERS, IOWA 51238-0421

DESCRIPTION SUPPORT, END BAR	
SCALE N.S.	PART NO. SJ15500

Copyright. All information furnished within this document, electronic file or design correspondence is the property of Den Hartog industries, Inc. and shall not be used, disclosed to others or copied without the expressed written consent of Den Hartog Industries, Inc.

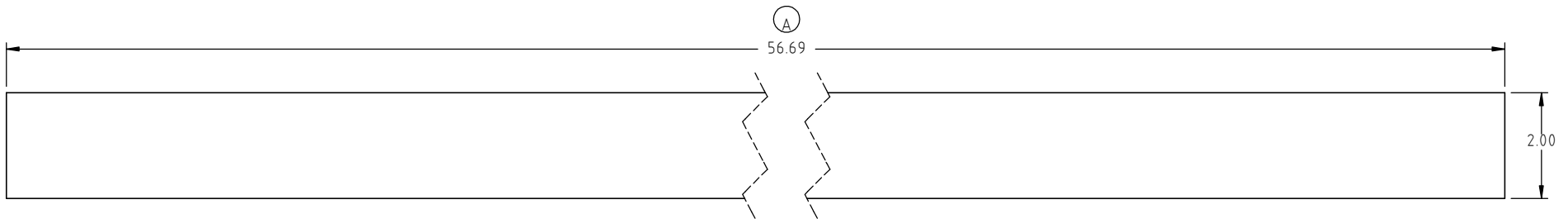

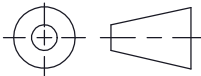
				DRAWN / DATE ADH 8/10/09	MATERIAL 1.) FLAT, 1/4" X 2" MILD STEEL	 <p><b>Den Hartog</b> INDUSTRIES, INC.</p> <p>Ace Roto-Mold Injection Molding Blow Molding Sowjoy</p> <p>4010 HOSPERS DRIVE S. BOX 425, HOSPERS, IOWA 51238-0421</p>	
A	56.69 WAS 56.50, .0625" WAS .125"	ADH 5/2/16	3246	APPROD. / DATE KGJ 4/27/10	2.) SHEAR FROM B02500X20000		
REV	DESCRIPTION	BY / DATE	CCN				
ALL DIMENSIONS ARE IN DECIMAL INCHES TOLERANCES UNLESS OTHERWISE SPECIFIED		THIRD ANGLE PROJECTION ANSI 14.5M		SHOT WEIGHT:	NOTES:	DESCRIPTION SUPPORT, CROSS	
POLYETHYLENE	METAL DECIMAL ± .062" (A) FRACTION ± 1/4" ANGLE ± 1°			SHIPPING WEIGHT:		SCALE N.S.	PART NO. SJ15502
±1% @ 68°F				FINISH:			