

Copyright. All information furnished within this document, electronic file or design correspondence is the property of Den Hartog industries, Inc. and shall not be used, disclosed to others or copied without the expressed written consent of Den Hartog Industries, Inc.

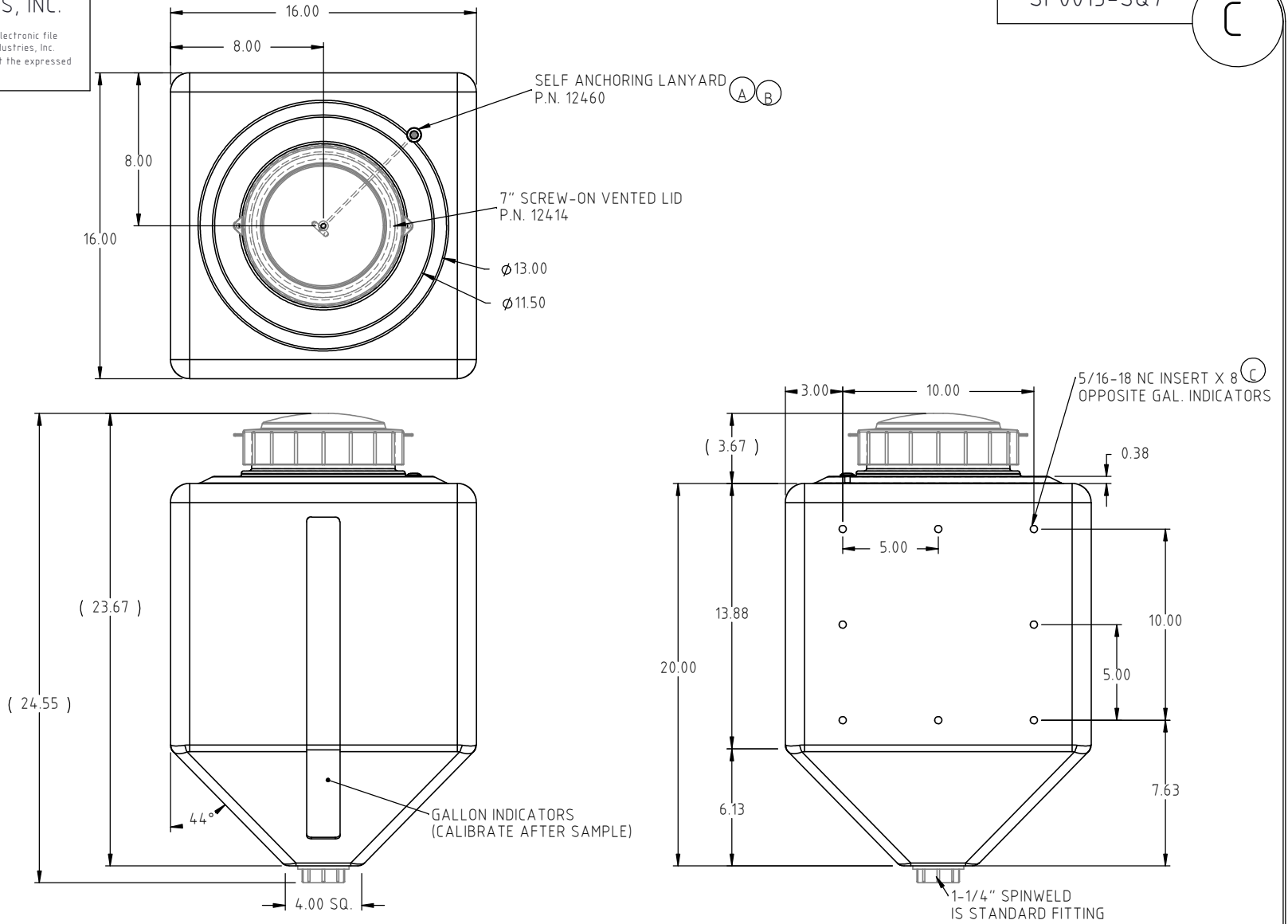

C	5/16 INSERT TYPO CORRECTED.	ADH 9/26/16	3291	DRAWN / DATE ADH 11/17/14	MATERIAL 10420 NATURAL
B	LANYARD LOCATION CORRECTED	ADH 5/26/16	3255	APPRD. / DATE REH 11/17/14	
A	12460 WAS SHOWN AS 10873	ADH 1/7/16	3186		
REV	DESCRIPTION	BY / DATE	CCN		
ALL DIMENSIONS ARE IN DECIMAL INCHES TOLERANCES UNLESS OTHERWISE SPECIFIED		THIRD ANGLE PROJECTION ANSI 14.5M		SHOT WEIGHT: 13.5 LBS.	NOTES: 1.) .250 NOMINAL WALL
POLYETHYLENE	METAL DECIMAL ± .125" FRACTION ± 1/4" ANGLE ± 1°	SHIPPING WEIGHT: 15.5 LBS		FINISH:	
±1% @ 68°F					



Den Hartog
INDUSTRIES, INC.

Ace Roto-Mold Injection Molding Blow Molding Sowjoy

4010 HOSPERS DRIVE S. BOX 425, HOSPERS, IOWA 51238-0425

DESCRIPTION 15 GALLON RINSE TANK-7" LID	
SCALE N.S.	PART NO. SP0015-SQ7