

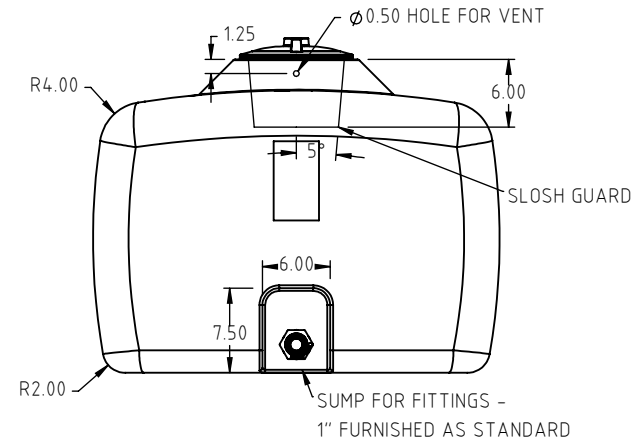

Copyright. All information furnished within this document, electronic file or design correspondence is the property of Den Hartog industries, Inc. and shall not be used, disclosed to others or copied without the expressed written consent of Den Hartog Industries, Inc.

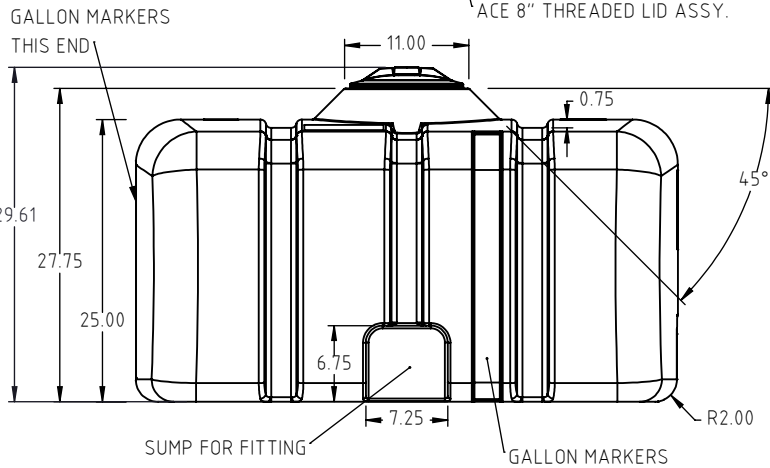

C	TOLERANCE WAS ± .5% @ 68° F	ADH 9/25/12	2494	DRAWN / DATE	MATERIAL MOBIL 134
B	CLARIFY SUMP LOCATION	ADH 2/14/07		REH / 4/19/99	
A	WEIGHT WAS 65 LB.	7/24/01		APPRD. / DATE	
REV	DESCRIPTION	BY / DATE	CCN	REH / 4/19/99	
ALL DIMENSIONS ARE IN DECIMAL INCHES TOLERANCES UNLESS OTHERWISE SPECIFIED		THIRD ANGLE PROJECTION ANSI 14.5M		SHOT WEIGHT: 60 LBS.	NOTES: 1.) NATURAL COLOR 2.) NOM. WALL .210
POLYETHYLENE (C) METAL DECIMAL ± .125" FRACTION ± 1/4" ANGLE ± 1°		±1% @ 68° F		SHIPPING WEIGHT: 61 LBS.	
		FINISH:			

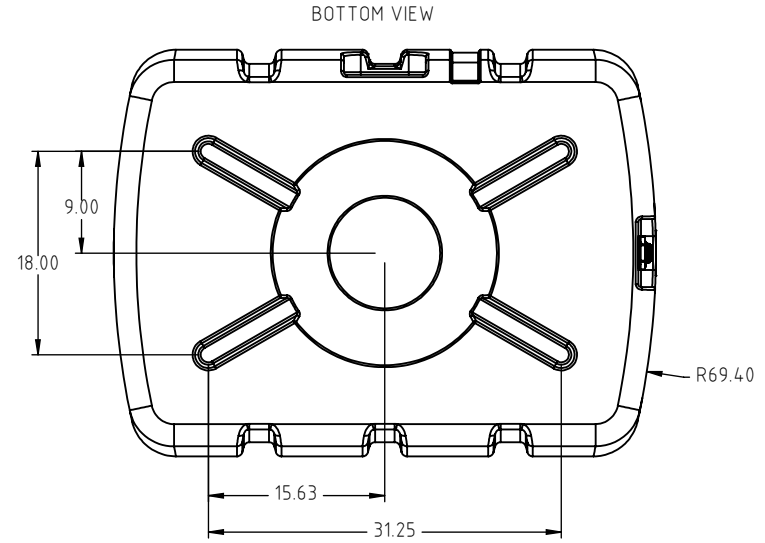
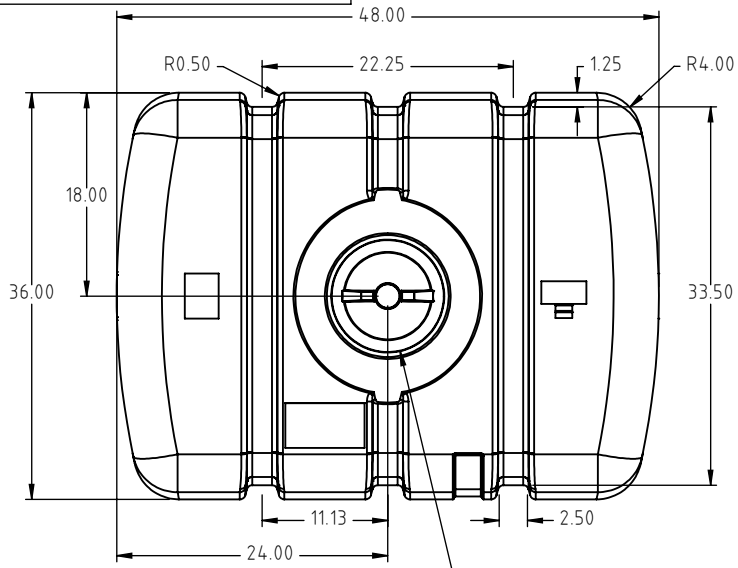

## Den Hartog

INDUSTRIES, INC.

Ace Roto-Mold Injection Molding Blow Molding Sowjoy

4010 HOSPERS DRIVE S. BOX 425, HOSPERS, IOWA 51238-0425

DESCRIPTION	150 GAL. TANK	
SCALE	N.S.	PART NO. SP0150-RT