

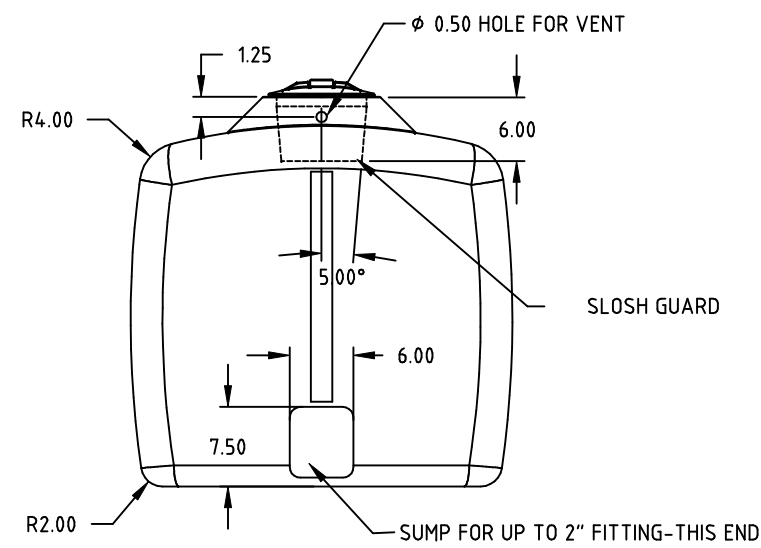

Copyright. All information furnished within this document, electronic file or design correspondence is the property of Den Hartog industries, Inc. and shall not be used, disclosed to others or copied without the expressed written consent of Den Hartog Industries, Inc.

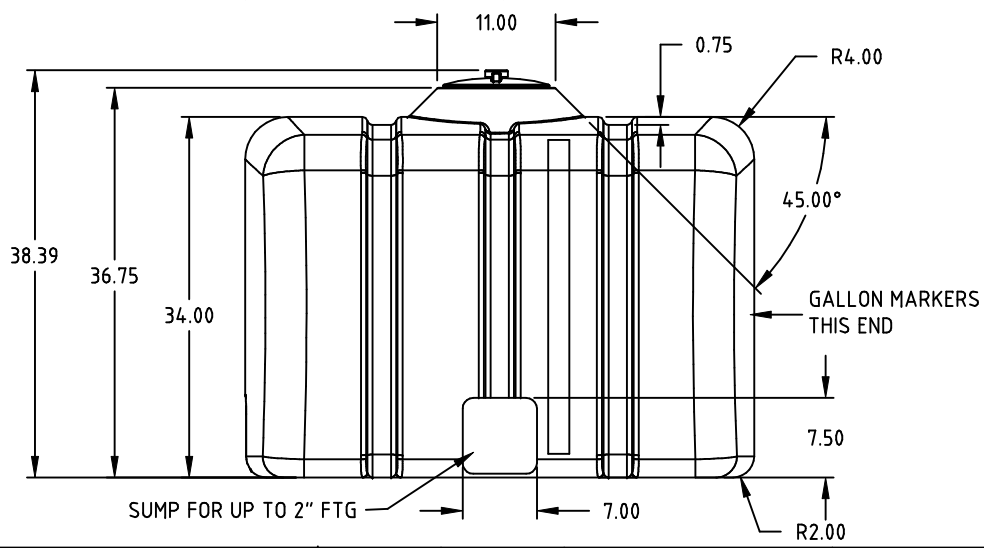
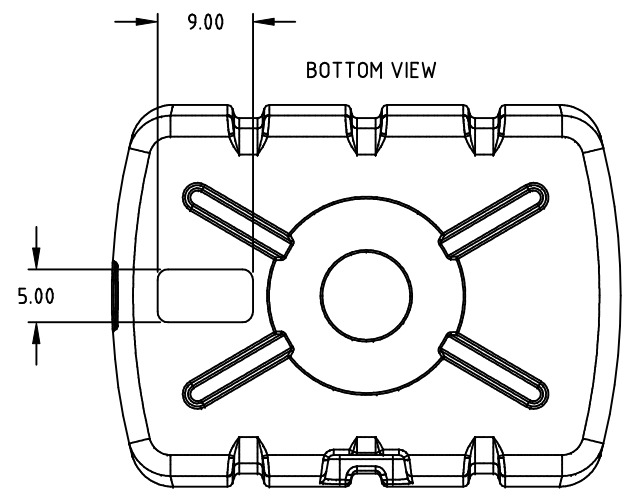
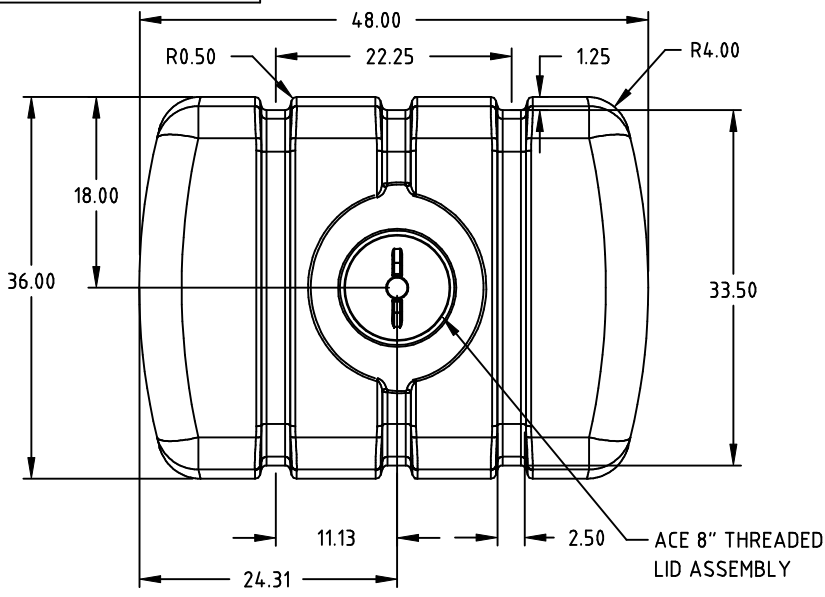

REV	DESCRIPTION	BY / DATE	CCN
A	GALLON MARKER LOCATION ADDED TO PRINT	ADH 12/10/09	1980
ALL DIMENSIONS ARE IN DECIMAL INCHES TOLERANCES UNLESS OTHERWISE SPECIFIED POLYETHYLENE		THIRD ANGLE PROJECTION ANSI 14.5M	
METAL DECIMAL ± .125" FRACTION ± 1/4" ANGLE ± 1°			

DRAWN / DATE	MATERIAL
REH / 4/19/99	MOBIL 134
APPRD. / DATE	
REH / 4/19/99	
SHOT WEIGHT:	NOTES:
80 LB.	1.) NATURAL COLOR
SHIPPING WEIGHT:	2.) NOM. WALL .270
FINISH:	

DESCRIPTION	200 GAL. TANK
SCALE	N.S.
PART NO.	SP0200-RT



Den Hartog

INDUSTRIES, INC.

Ace Roto-Mold Injection Molding Blow Molding Sowjoy
4010 HOSPERS DRIVE S. BOX 425, HOSPERS, IOWA 51238-0425