

© DEN HARTOG INDUSTRIES, INC.

Copyright. All information furnished within this document, electronic file or design correspondence is the property of Den Hartog Industries, Inc. and shall not be used, disclosed to others or copied without the expressed written consent of Den Hartog Industries, Inc.

SP0750-UT

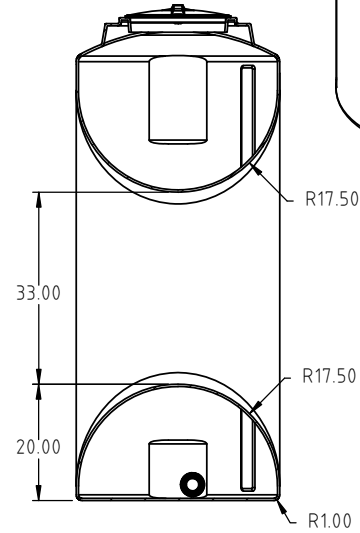
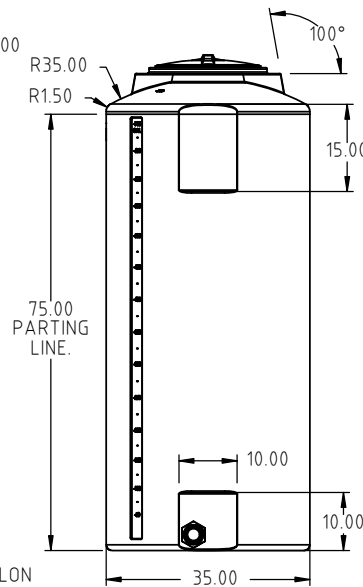
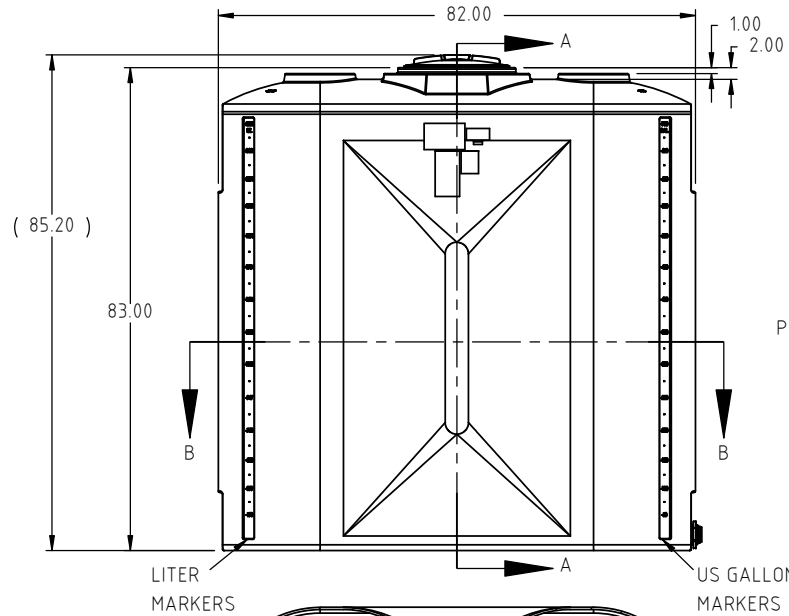
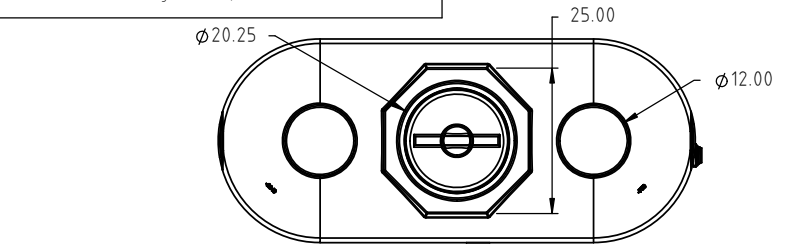

SECTION A-A  
SCALE 1:33

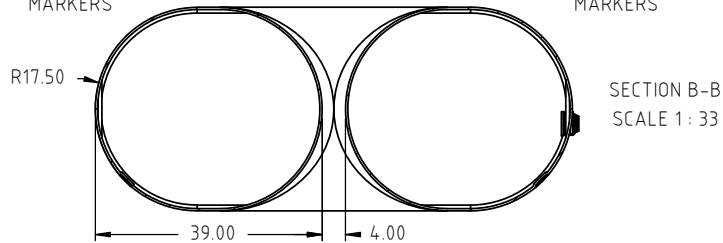

SECTION B-B  
SCALE 1:33

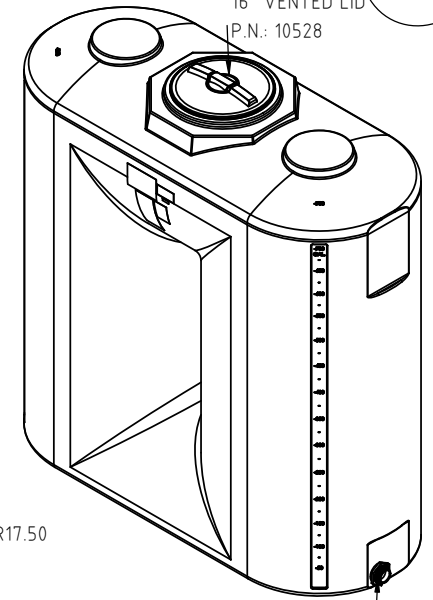

2" FPT FITTING IS STANDARD.  
P.N.: 10508  
(OFFSET FROM P/L)

REV	DESCRIPTION	BY / DATE	CCN	DRAWN / DATE ADH 9/26/17	MATERIAL 10538
				APPRD. / DATE REH 3/13/18	
ALL DIMENSIONS ARE IN DECIMAL INCHES TOLERANCES UNLESS OTHERWISE SPECIFIED		THIRD ANGLE PROJECTION ANSI 14.5M		SHOT WEIGHT: 316 LBS.	NOTES: 1.) NOM. WALL .400
POLYETHYLENE		METAL DECIMAL ± .125" FRACTION ± 1/4" ANGLE ± 1°		SHIPPING WEIGHT: 318 LBS.	
±1% @ 68°F				FINISH:	



**Den Hartog**  
INDUSTRIES, INC.

Ace Roto-Mold Injection Molding Blow Molding Sowjoy

4010 HOSPERS DRIVE S. BOX 425, HOSPERS, IOWA 51238-0425

DESCRIPTION	750 GALLON UTILITY TANK	
SCALE	N.S.	PART NO. SP0750-UT