

Copyright. All information furnished within this document, electronic file or design correspondence is the property of Den Hartog Industries, Inc. and shall not be used, disclosed to others or copied without the expressed written consent of Den Hartog Industries, Inc.

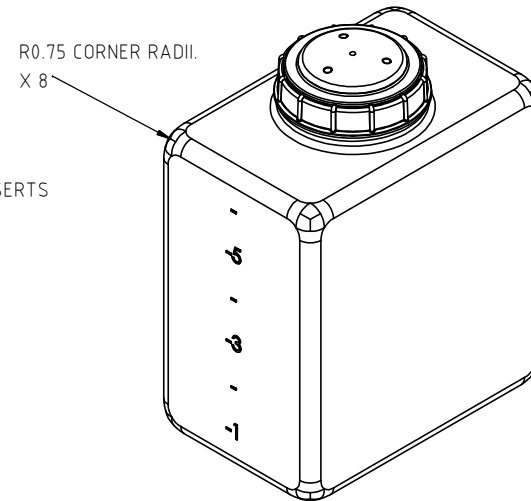

NOTE: THIS PRODUCT IS NOT DESIGNED TO CONTAIN PETROLEUM PRODUCTS. CONSULT THE FACTORY REGARDING CHEMICAL COMPATIBILITY

				DRAWN / DATE ADH 4/10/20	MATERIAL 80001
				APPROD. / DATE REH 7/14/20	
REV	DESCRIPTION	BY / DATE	CCN		
ALL DIMENSIONS ARE IN DECIMAL INCHES TOLERANCES UNLESS OTHERWISE SPECIFIED		THIRD ANGLE PROJECTION ANSI 14.5M		SHOT WEIGHT: 7 LBS.	NOTES: 1.) NATURAL COLOR
POLYETHYLENE		METAL DECIMAL ± .125" FRACTION ± 1/4" ANGLE ± 1°		SHIPPING WEIGHT:	
±1% @ 68°F				FINISH:	

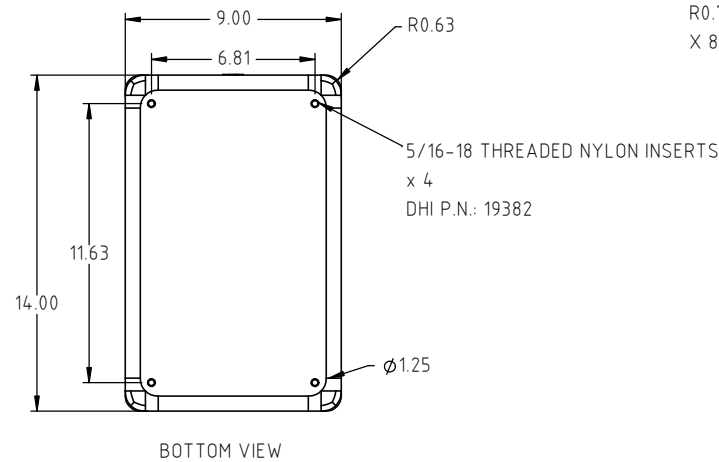
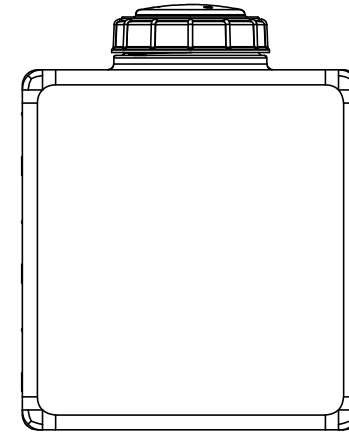
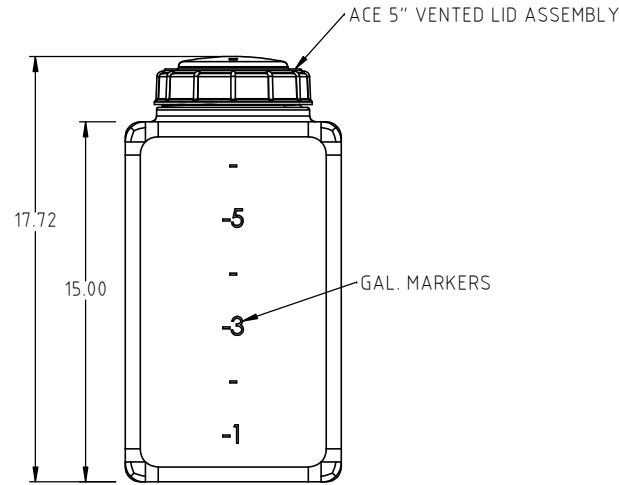

Den Hartog
INDUSTRIES, INC.

Acra Roto-Mold Injection Molding Blow Molding Sowjoy

4010 HOSPERS DRIVE S. BOX 425, HOSPERS, IOWA 51238-0425

DESCRIPTION 7 GALLON RECTANGULAR TANK-BLOW MOLDED	
SCALE N.S.	PART NO. SPBM0007-RT