

© DEN HARTOG INDUSTRIES, INC.

Copyright. All information furnished within this document, electronic file or design correspondence is the property of Den Hartog Industries, Inc. and shall not be used, disclosed to others or copied without the expressed written consent of Den Hartog Industries, Inc.

SPBM05-SQ7

C

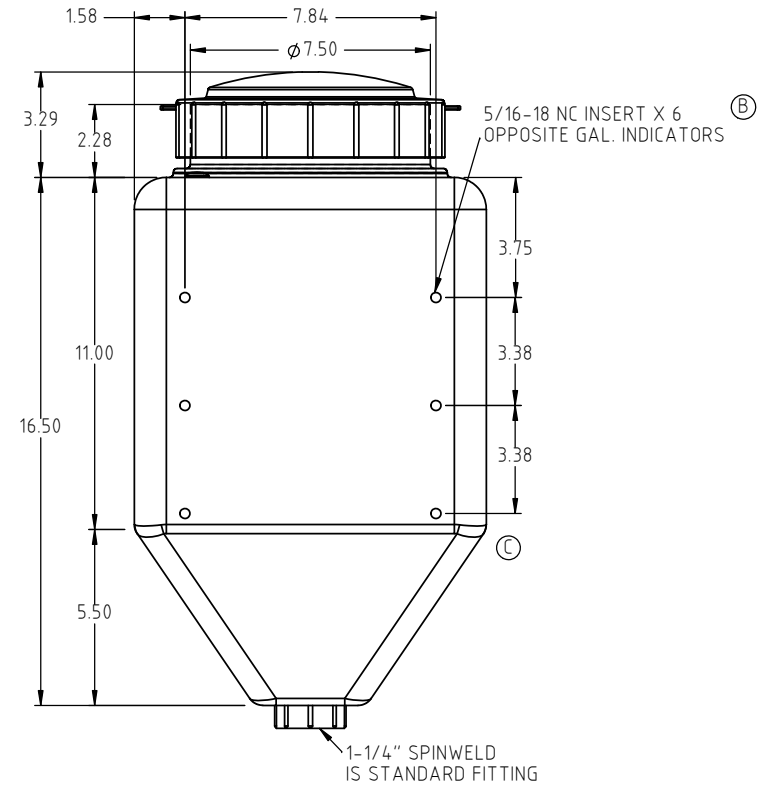
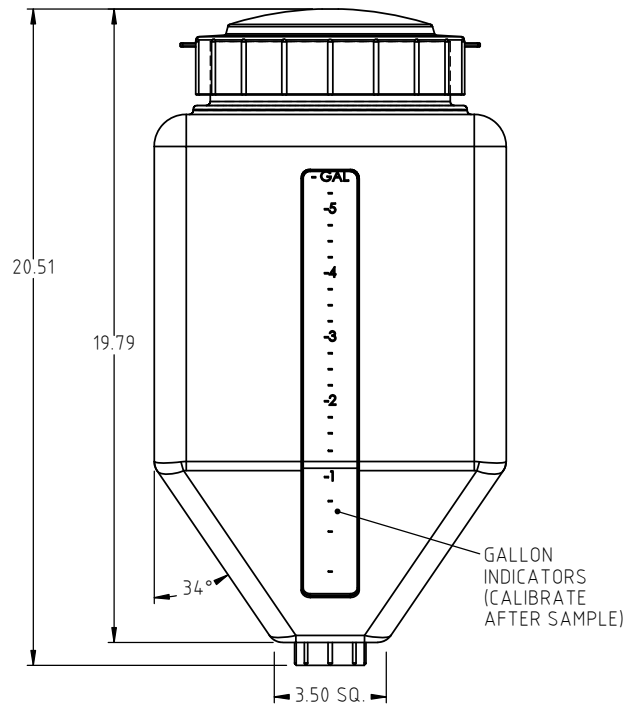
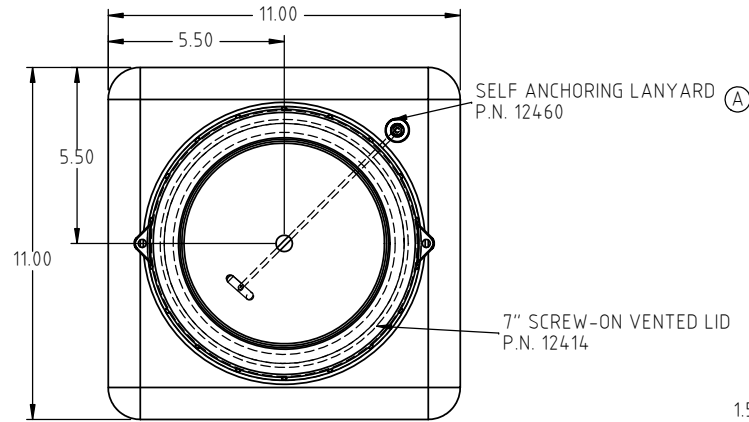

C	DIMENSION REMOVED.	DHJ 6/24/20	3978	DRAWN / DATE	MATERIAL
B	5/16 INSERT TYPO CORRECTED.	ADH 9/28/16	3291	ADH 4/24/13	WHITE=80001
A	LANYARD LOCATION CORRECTED.	ADH 5/13/15	3065	APPRD. / DATE	YELLOW=80001 80003
REV	DESCRIPTION	BY / DATE	CCN	REH 10/17/13	
ALL DIMENSIONS ARE IN DECIMAL INCHES TOLERANCES UNLESS OTHERWISE SPECIFIED		THIRD ANGLE PROJECTION ANSI 14.5M		SHOT WEIGHT: 5.00 LBS	NOTES: 1.) SHIP PART W/CAP INSTALLED
POLYETHYLENE		METAL DECIMAL ± .125" FRACTION ± 1/4" ANGLE ± 1°		SHIPPING WEIGHT: 5.75 LBS	
±1% @ 68°F				FINISH:	



Den Hartog
INDUSTRIES, INC.

Ace Roto-Mold Injection Molding Blow Molding Sowjoy

4010 HOSPERS DRIVE S. BOX 425, HOSPERS, IOWA 51238-0425

DESCRIPTION	ACE 5 GAL. MINI-INDUCTOR TANK-7" LID	
SCALE	N.S.	PART NO. SPBM05-SQ7