

© DEN HARTOG INDUSTRIES, INC.

Copyright. All information furnished within this document, electronic file or design correspondence is the property of Den Hartog Industries, Inc. and shall not be used, disclosed to others or copied without the expressed written consent of Den Hartog Industries, Inc.

SPBM2.5-RT

B

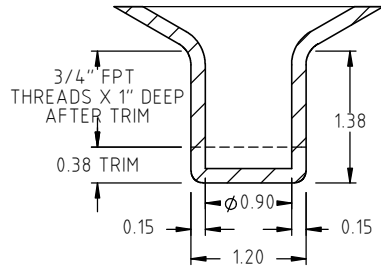

SECTION B-B
SCALE 1:2

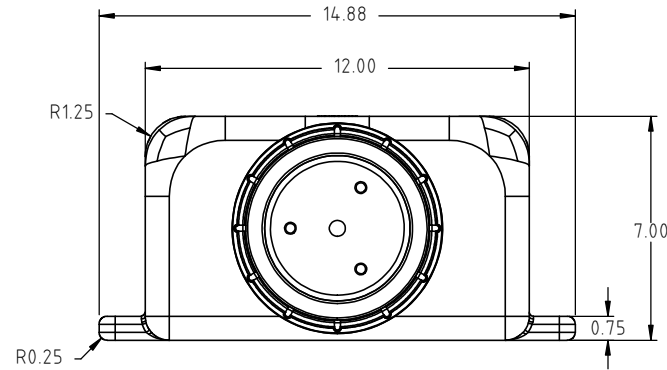

ⓑ 13696
5" VENTED LID

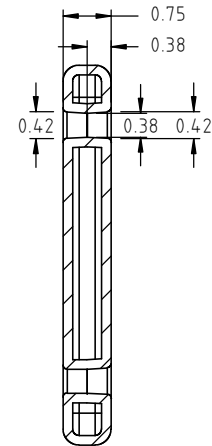
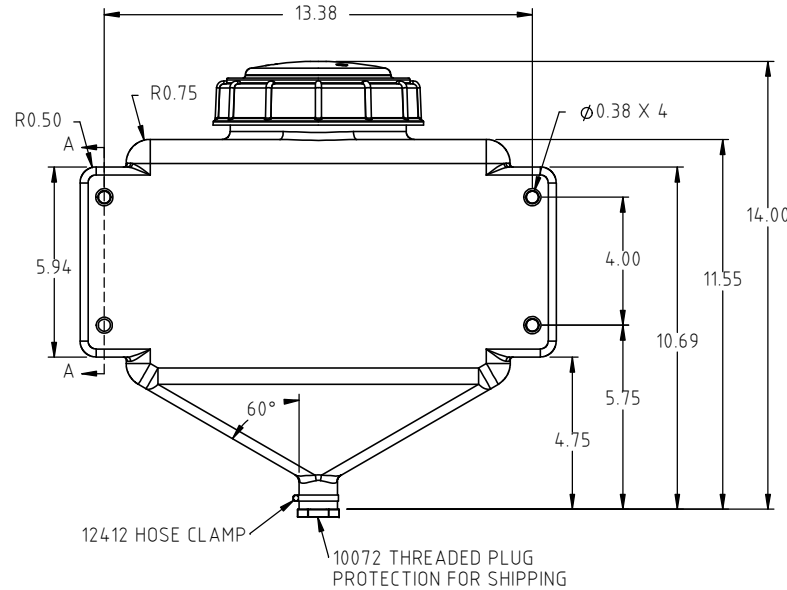
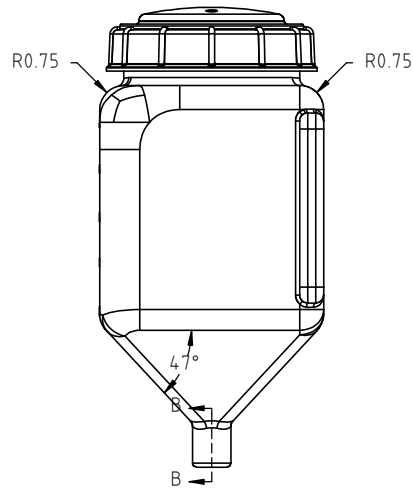
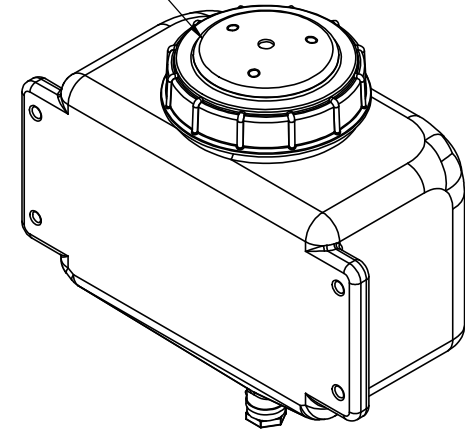

SECTION A-A
SCALE 1:3

REV	DESCRIPTION	BY / DATE	CCN	DRAWN / DATE	MATERIAL
B	3.5 LBS WAS 3.0 LBS, 13696 INCORRECTLY SHOWN AS 10522	ADH 9/13/13	2688	ADH 6/25/13	EQUISTAR 5704
A	BLOW MOLDED P.N. CREATED FOR 2.50 GALLON WHITE/YELLOW TANKS ONLY	ADH 6/25/13	2641	APPRD. / DATE	
				REH 6/25/13	
ALL DIMENSIONS ARE IN DECIMAL INCHES TOLERANCES UNLESS OTHERWISE SPECIFIED		THIRD ANGLE PROJECTION ANSI 14.5M		SHOT WEIGHT: 3.0 LBS	NOTES: 1.) WHITE OR YELLOW COLOR 2.) NOM. WALL = .150
POLYETHYLENE				SHIPPING WEIGHT: 3.5 LBS	
±1% @ 68°F				FINISH: ⓑ	DESCRIPTION: 2-1/2 GALLON SPECIALTY TANK-BLOW MOLDED



Den Hartog
INDUSTRIES, INC.

Ace Roto-Mold Injection Molding Blow Molding Sowjoy

4010 HOSPERS DRIVE S. BOX 425, HOSPERS, IOWA 51238-0425

SCALE	N.S.	PART NO.	ⓐ SPBM2.5-RT
-------	------	----------	--------------