

Copyright. All information furnished within this document, electronic file or design correspondence is the property of Den Hartog Industries, Inc. and shall not be used, disclosed to others or copied without the expressed written consent of Den Hartog Industries, Inc.

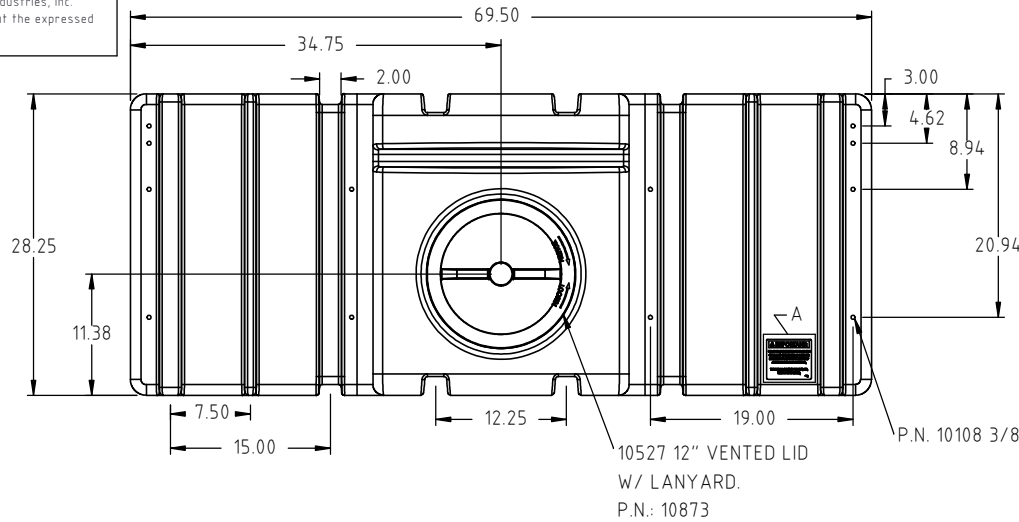

⚠ IMPORTANT:

USE AT LEAST SIX INSERTS ON EACH SIDE OF TANK TO SECURE FRAME WORK OR MOUNTING PLATE FOR ENGINE/PUMP AND HOSE REEL IF SO EQUIPPED.

TORQUE ALL BOLTS TO 12-15 FT. LBS. WITH LOCK WASHERS.

14723

LABEL P.N.: 14723
DETAIL A
SCALE 1:2

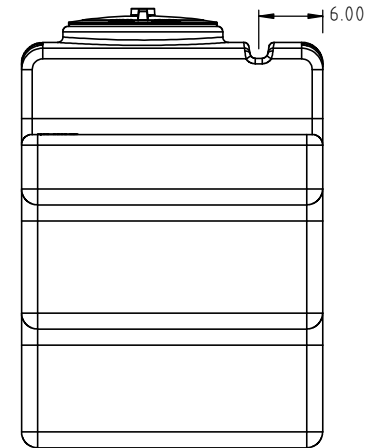
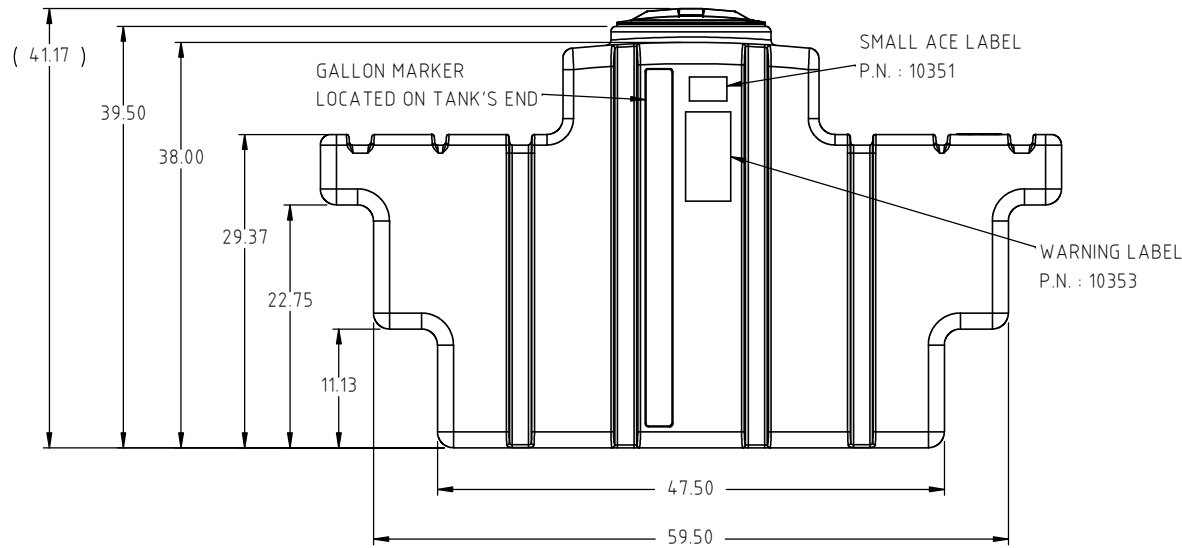

				DRAWN / DATE ADH 8/18/17	MATERIAL 14575 1.7 MELT NATURAL
				APPROD. / DATE REH 8/18/17	
REV	DESCRIPTION	BY / DATE	CCN	SHOT WEIGHT: 118.0 LBS.	NOTES: 1.325 WALL
	ALL DIMENSIONS ARE IN DECIMAL INCHES TOLERANCES UNLESS OTHERWISE SPECIFIED			SHIPPING WEIGHT: 120.0 LBS.	
	POLYETHYLENE ±1% @ 68°F	METAL DECIMAL ± .125" FRACTION ± 1/4" ANGLE ± 1°	THIRD ANGLE PROJECTION ANSI 14.5M 	FINISH:	



Den Hartog
INDUSTRIES, INC.

Ace Roto-Mold Injection Molding Blow Molding Sowjoy

4010 HOSPERS DRIVE S. BOX 425, HOSPERS, IOWA 51238-0425

DESCRIPTION 200 GALLON SPACE SAVER TANK	
SCALE N.S.	PART NO. SSPU0200-70