

Copyright. All information furnished within this document, electronic file or design correspondence is the property of Den Hartog industries, Inc. and shall not be used, disclosed to others or copied without the expressed written consent of Den Hartog Industries, Inc.

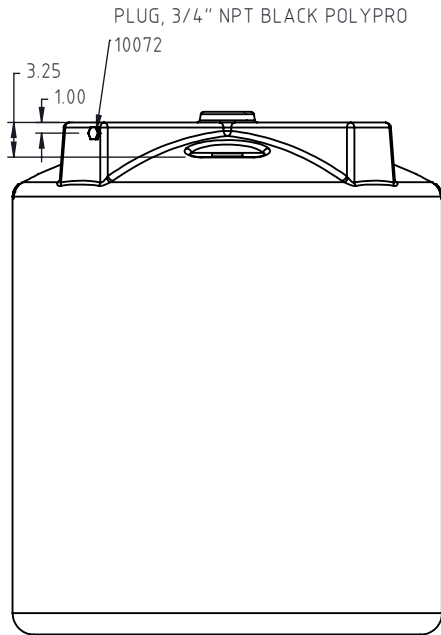

BACK OF TANK

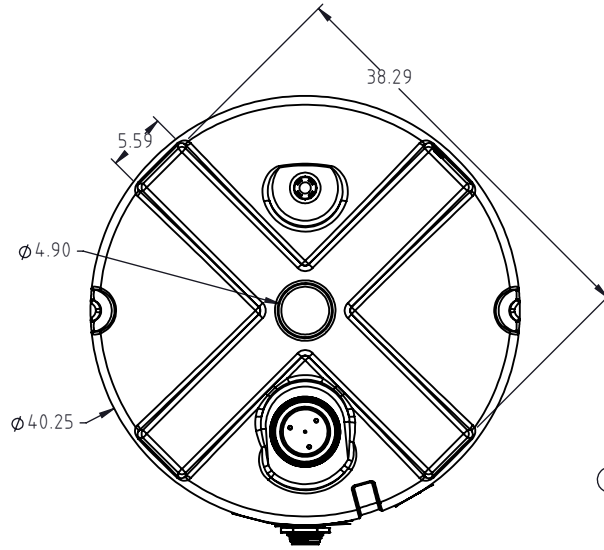
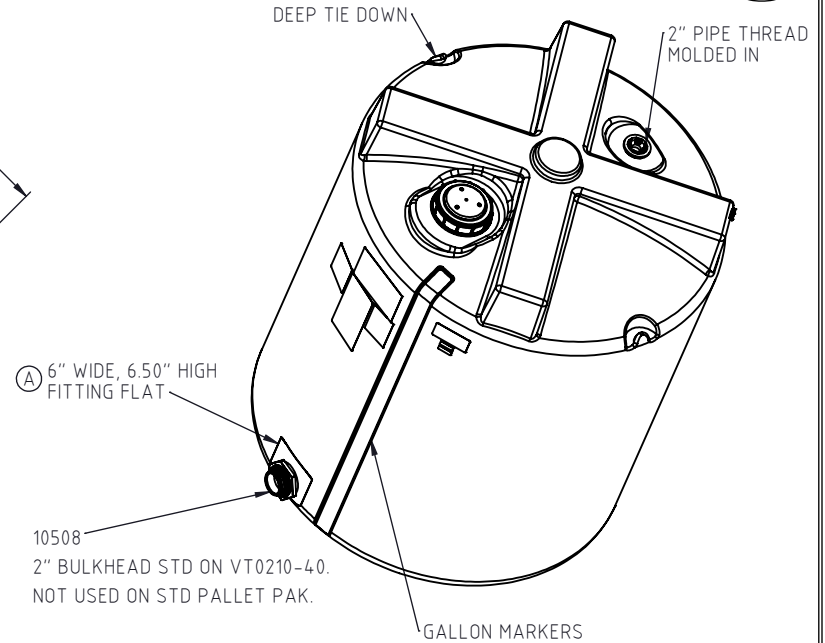
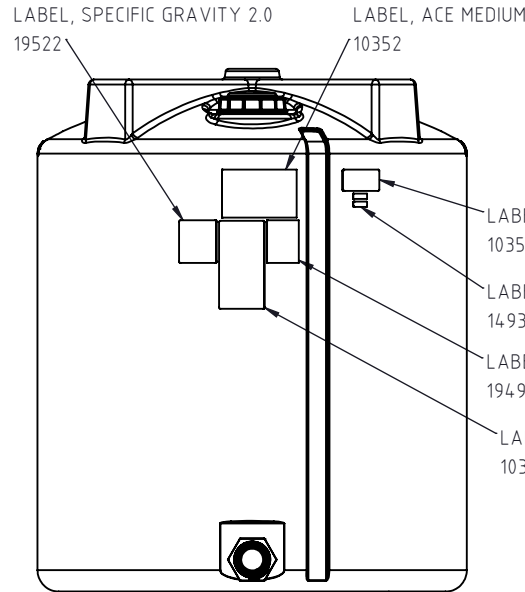

B	STANDARD FITTING, 10072 PLUG, LABELS NOTED. PRINT LAYOUT UPDATED.	ADH	1/13/2023	4375
A	FLAT DIMENSION ADDED.	ADH	8/18/2008	1701
REV.	DESCRIPTION	BY	DATE	CCN
ALL DIMENSIONS ARE IN DECIMAL INCHES TOLERANCES UNLESS OTHERWISE SPECIFIED		THIRD ANGLE PROJECTION ANSI 14.5M		
POLYETHYLENE ±1% @ 68°F				
METAL DECIMAL ± .125" FRACTION ± 1/4" ANGLE ± 1°				

DRAWN / DATE NVE 6/28/2005	MATERIAL : HDPE OR EQUIVALENT REFERENCE MATERIAL DATA SHEET FOR SPECIFIC PROPERTIES.
APPRD. / DATE DHJ 6/28/2005	
SHOT WEIGHT: 56.00 LBS.	NOTES: 1.) WHITE COLOR.
SHIPPING WEIGHT: 58.00 LBS.	
FINISH:	

# Den Hartog INDUSTRIES, INC.

Ace Roto-Mold • Injection Molding • Blow Molding • Sowjoy  
4010 HOSPERS DRIVE S. BOX 425, HOSPERS, IOWA 51238-0425

DESCRIPTION 210 GALLON VERTICAL TANK		
SCALE N.S.	PART NO. VT0210-40	SHEET 1 OF 1