

© DEN HARTOG INDUSTRIES, INC.

Copyright. All information furnished within this document, electronic file or design correspondence is the property of Den Hartog industries, Inc. and shall not be used, disclosed to others or copied without the expressed written consent of Den Hartog Industries, Inc.

VT0300-40

A

KEY	PART NUMBER	DESCRIPTION	QTY.
1	13696	LID, 5" VENTED W/SPRING, BLACK DHI	1
2	13806	2" BULKHEAD WITH SHORT SYPHON	1
3	10691	CAP PLUG, 2" T25A	1
4	10352	LABEL, ACE MEDIUM	1
5	10357	LABEL, BARCODE 4" X 2"	1
6	10353	LABEL, WARNING	1
7	14935	LABEL, PROP 65	1
8	19496	NSF/ANSI/CAN 61 MARKING LABEL	1
9	19522	LABEL, SPECIFIC GRAVITY 2.0	1
10	XXXX	LABEL, INSPECTION	1

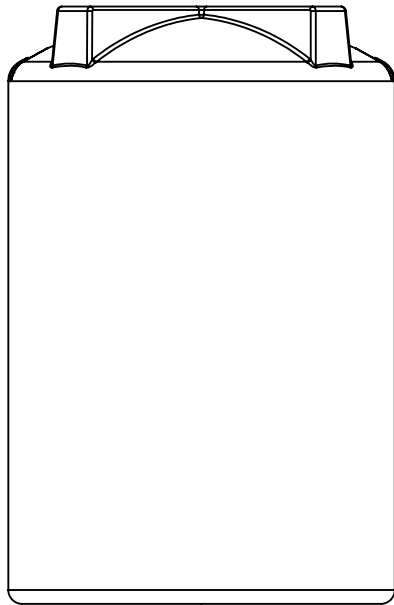
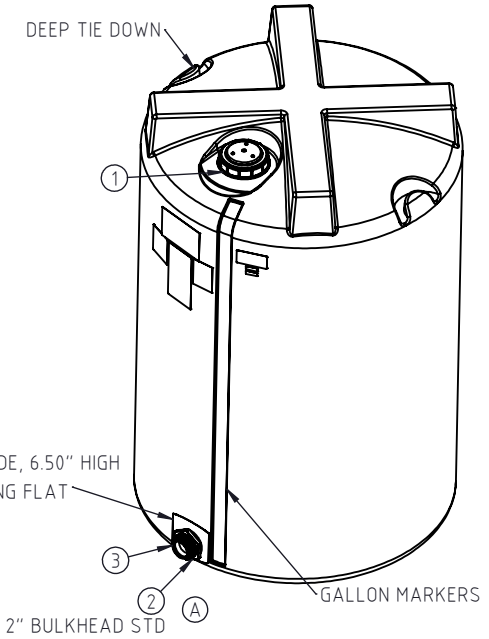
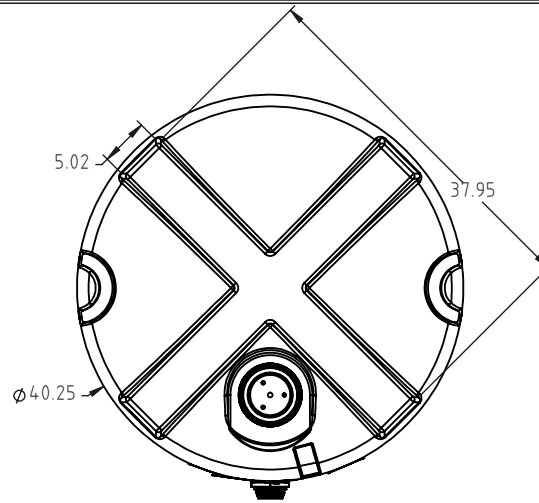

BACK OF TANK

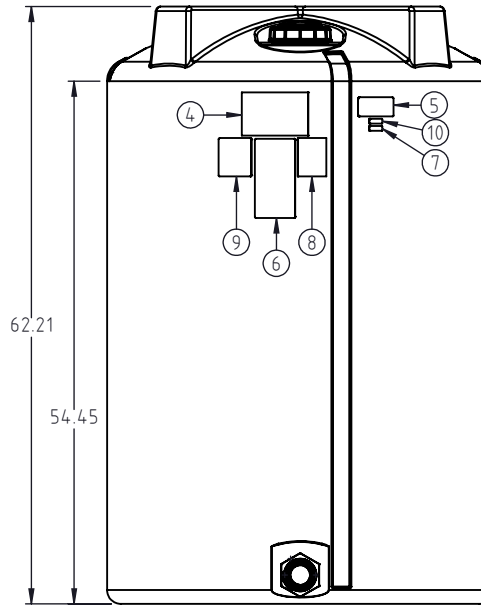

A	13806 WAS 10508	AJH	1/30/2026	4816
REV.	DESCRIPTION	BY	DATE	CCN
ALL DIMENSIONS ARE IN DECIMAL INCHES TOLERANCES UNLESS OTHERWISE SPECIFIED		THIRD ANGLE PROJECTION ANSI 14.5M		
POLYETHYLENE	METAL			
±1% @ 68°F	DECIMAL ± .125" FRACTION ± 1/4" ANGLE ± 1°			

DRAWN / DATE	MATERIAL :
ADH 5/1/2025	LLDPE
APPRD. / DATE	NOTES:
BES 5/14/2025	SHOT WEIGHT: 68.00 LBS.
	SHIPPING WEIGHT: 70.00 LBS.
	FINISH:
	NOMINAL WALL THICKNESS: 0.2"

Den Hartog

INDUSTRIES, INC.

Ace Roto-Mold • Injection Molding • Blow Molding • Sowjoy
4010 HOSPERS DRIVE S. BOX 425, HOSPERS, IOWA 51238-0425

DESCRIPTION 300 GALLON VERTICAL TANK		
SCALE N.S.	PART NO. VT0300-40	SHEET 1 OF 1