

© DEN HARTOG INDUSTRIES, INC.

Copyright. All information furnished within this document, electronic file or design correspondence is the property of Den Hartog industries, Inc. and shall not be used, disclosed to others or copied without the expressed written consent of Den Hartog Industries, Inc.

VT15500-142

A

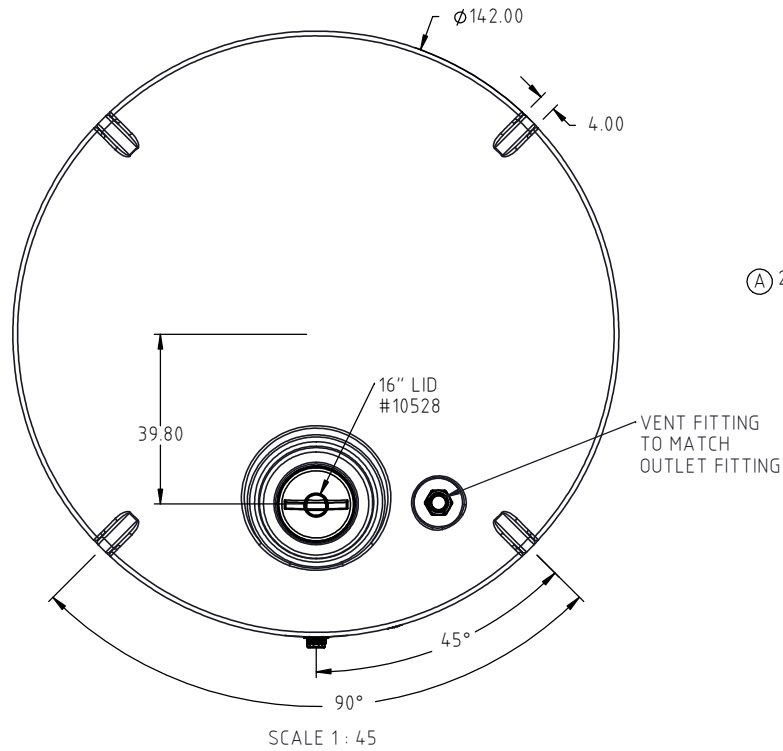

Ⓐ 242.50

206.50

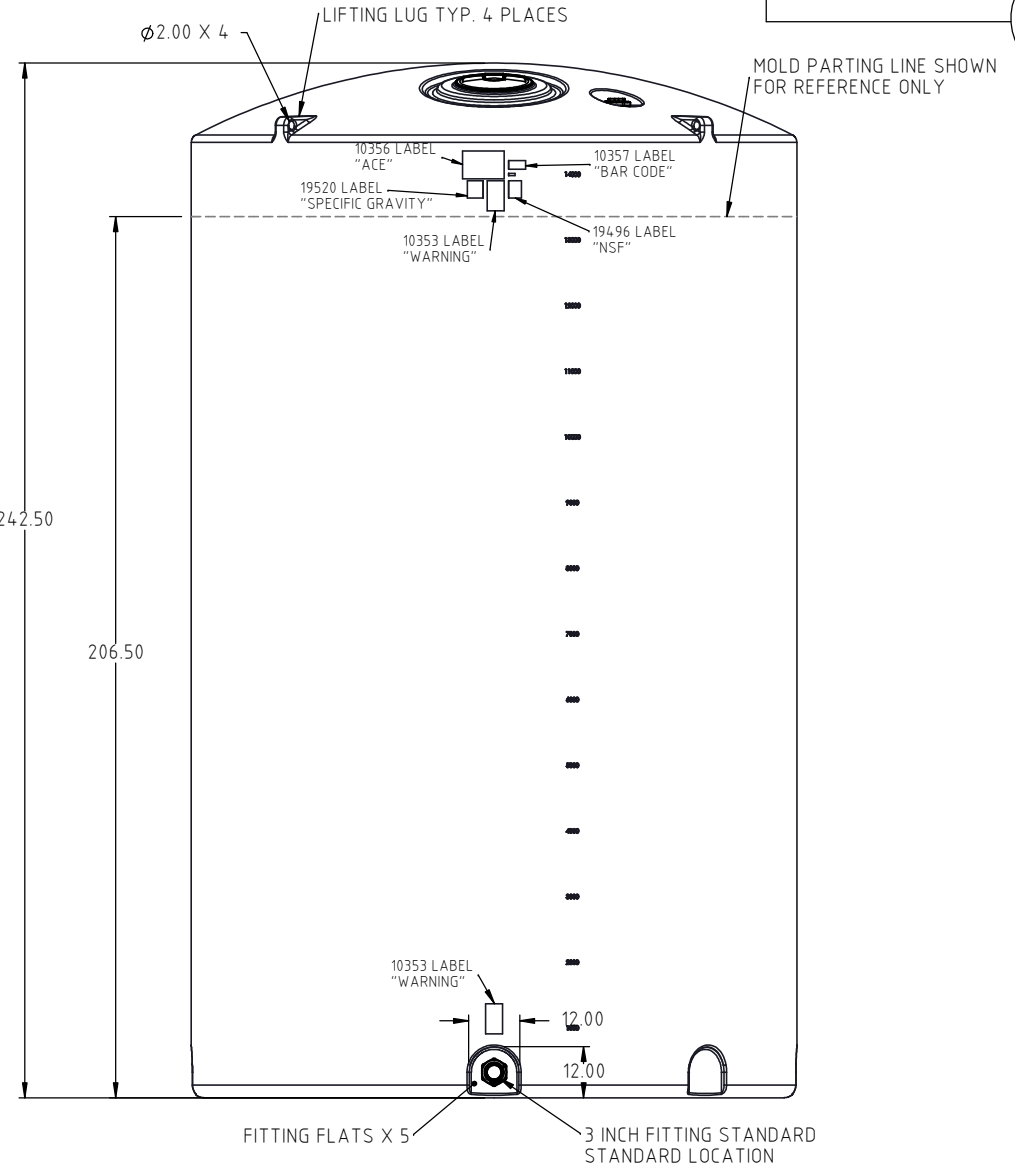

				DRAWN / DATE ADH 5/16/14	MATERIAL 10538 2 MELT RESIN
A	242.50" WAS 246.50" ON THE PRINT	DHJ 11/8/17	3462	APPRO. / DATE REH 6/1/16	
REV	DESCRIPTION	BY / DATE	CCN		
ALL DIMENSIONS ARE IN DECIMAL INCHES TOLERANCES UNLESS OTHERWISE SPECIFIED		THIRD ANGLE PROJECTION ANSI 14.5M		SHOT WEIGHT: 4 000 LBS	NOTES: 1.) WHITE, BLACK, OR YELLOW COLOR 2.) THICKNESS AT FITTING 1.65 FOR 1.7 SPECIFIC GRAVITY
POLYETHYLENE ±1% @ 68°F		METAL DECIMAL ± .125" FRACTION ± 1/4" ANGLE ± 1°		SHIPPING WEIGHT: 4 002 LBS	
		FINISH:			



Den Hartog
INDUSTRIES, INC.

Acra Roto-Mold Injection Molding Blow Molding Sowjoy

4010 HOSPERS DRIVE S. BOX 425, HOSPERS, IOWA 51238-0425

DESCRIPTION 15500 GALLON VERTICAL TANK	
SCALE N.S.	PART NO. VT15500-142